



PORSCHE

PETER
MILLER
BOOKS + SUPPLIES



The new Panamera Sport Turismo

Venture on



6	Sports car fascination
8	Panamera Sport Turismo concept
16	Design
38	Drive and chassis
66	Environment
68	Comfort and infotainment
88	Porsche Connect
94	Lights and vision
96	Assistance systems
106	Personalisation
110	Porsche Exclusive Manufaktur
156	Porsche World
158	Technical data
170	Index



'In the beginning I looked around and could not find quite the car I dreamed of. So I decided to build it myself.'

Ferry Porsche

The dream of the sports car.

A big dream has to be fought for. And so does a bold vision. The next victory? Rarely does it simply fall into our lap. Often, there are innate factors we must compete against first: resistance, conventions, and rigid patterns of thinking.

Whatever we put our heart and soul into, nothing is achieved without passion, grit and determination. Ferry Porsche gave everything for the sports car of his dreams. His dream came true. Not because he hesitated, dwelled or got lucky, but because he went that extra mile.

This attitude is in every Porsche that we've created since 1948. It's there in the smallest part and in every race we've won. It's also found in every idea. That's because our engineers are not satisfied with 100 %. It's because they give their all. For that one crucial percentage point more. For the one second that means the difference between triumph and despair. For the 'Dr. Ing.' in our company name and for the chance to stir the passion for the sports car time and time again.

To us, it's never been about extra horsepower alone, but about more ideas per hp. It's about engines that are more efficient, not bigger. It's about a design that follows principles, not trends. It's about sports cars that can be driven day in, day out.

It's only when all these things come together that we can talk of Intelligent Performance – the core of the Porsche brand, and of its future. This is what we are fighting for. Just as we did on day one. We are fighting for a dream that will forever be in our heart.



Concept.

The most powerful driving force of all time? Dreams.
And the courage to make them a reality.



Your life is getting there.

Panamera Sport Turismo concept.

Life does not wait. It calls for progress every day. It's moody. It pursues us, pushing us onwards, never leaves us in peace. And it constantly surprises us with unexpected turns. Isn't that great?

Before you stands a sports car. One that puts into action everything you need to get ahead. In your job. In your everyday life. And away from it. In-tray full of projects? Places you've always wanted to visit? Sporty goals unfulfilled? Let's go.

Accept, implement, perform. That is the principle of the Panamera Sport Turismo. A car characterised by unequivocal sportiness, excellent everyday practicality and a design that sets new standards not only at Porsche. A segment? Doesn't fit in one. And certainly not a niche. It would much rather conquer the road directly.

Driven by a new generation of high-powered engines. The courage to defy conventions drives it forwards. A genuine Porsche? An atypical Panamera? The new Panamera Sport Turismo is defined, primarily, by itself.

Made for those who don't wait to be told what to do next. For all those who have the courage to get up and go. Preferably straight away.

The new Panamera Sport Turismo.
Venture on.

The new Sport Turismo models precisely encapsulate the Panamera principle: performance and comfort are not contradictory notions, but a single entity. Neither are dynamics and efficiency – our engineers strive to enhance both in equal measure.

That's all well and good but, in Sport Turismo form, the new Panamera goes one step further, not only in terms of design. Instead of seeking compromises, it manages in unrivalled style to strike a dynamic balance between career, family, leisure time and driving pleasure. 4+1 seating concept. Generous head- and legroom. Substantial load capacity – for presentation folders, for the carbon-fibre race bike, for your travel luggage. Or for that meeting with a special VIP: you.





The new Panamera Sport Turismo sees five drive system variants take to the grid. The Panamera 4 Sport Turismo with 3.0-litre turbocharged V6 engine and a power output of 243 kW (330 hp). The Panamera 4 E-Hybrid Sport Turismo with a total system power output of 340 kW (462 hp). In the Panamera 4S Sport Turismo, the 2.9-litre twin-turbo V6 engine produces a mighty 324 kW (440 hp). Driving force in the Panamera Turbo Sport Turismo: the 4.0-litre twin-turbo V8 engine offering an awe-inspiring 404 kW (550 hp). The Panamera Turbo S E-Hybrid Sport Turismo pushes performance to the limit with an impressive system performance of 500 kW (680 hp).

Chassis control systems, such as Porsche Dynamic Chassis Control Sport (PDCC Sport) or rear-axle steering, intensify the driving experience – and safety. Assistance systems, such as Porsche InnoDrive, make it safer and more relaxing. Thanks to Porsche Connect, all Panamera Sport Turismo models are connected to the digital world. Just what you need when you're on a journey to the future.

For fuel consumption, CO₂ emissions, electricity consumption and efficiency class, please refer to page 166 onwards.

Design.

Never being what anyone thinks a Porsche ought to be.
That's why it will always be a Porsche.





Essentially, style is nothing but the courage to follow a line of your own.

Exterior design.

A saloon? A sports car? Let's drop this subject. In the design alone, the new Panamera Sport Turismo has no concept of forbidden thoughts. Categories are not something it allows itself to fall into. Instead, it demonstrates courage. It does so with edge, with sporty vigour and the healthy self-awareness of a Porsche.

Let's start with the aspect of a Porsche that always attracts the most attention: the back. The rear end displays a wide physique and is clearly contoured, with all lines emphasising the horizontal orientation of the vehicle concept. The newly refined, higher roof line falls away to the rear, the large-size rear side windows narrow to a point. Nevertheless, passengers in the second row still have plenty of room to get in. A sports car: sharp, agile, contemporary.

The adaptive roof spoiler above the large-area rear window is exceptional. At high speeds it reduces the lift on the rear axle and provides excellent driving stability, high performance and more driving pleasure.

Conspicuous, in the best sense of the word, describes the light strip on the rear end and the three-dimensionally shaped LED taillights with four-point brake lights. Characteristic of the stylish look commanded by the Panamera Turbo Sport Turismo and the Panamera Turbo S E-Hybrid Sport Turismo are the imposing Turbo-specific twin tailpipes. The Panamera 4S is equipped with round twin tailpipes, the Panamera 4 models with a single tailpipe on the right and left.

The fact that stylish design and everyday practicality are not mutually exclusive is demonstrated by the large tailgate and the low loading edge, which makes it easier to integrate more than just everyday things into the Panamera Sport Turismo – and your life. Thanks, above all, to – for a sports car – an extraordinary capacity of up to 1,390 litres (more on p. 80).

1 Roof spoiler deployed

2 Roof spoiler retracted

In a sports car, the rear view shows the sporty attitude. Front and side, however, reveal a lot about the elegance and lines of the vehicle concept.

From this perspective, the proportions of the new Panamera Sport Turismo models are above all one: Porsche. The defined edges, the powerful muscles and a sharpened eye Sports car silhouette.

The wheelbase is long, in front the overhang is comparatively short, which strengthens the dynamic impression. The side is strongly sculptured, creating a characteristic waist and light appearance for Porsche.

An identifying feature of the new Panamera Turbo Sport Turismo and the new Panamera Turbo S E-Hybrid Sport Turismo: the side air outlets in the front wings are finished in the exterior colour of the car. They underline – along with the distinctive front end featuring characteristic front light units – the dominant position that the Panamera Turbo Sport Turismo maintains.

A hallmark of all Panamera models: LED main headlights with four-point daytime running lights, supplemented on the Panamera Turbo Sport Turismo and the Panamera Turbo S E-Hybrid Sport Turismo by the Porsche Dynamic Light System (PDLS).

The Panamera Turbo S E-Hybrid Sport Turismo stands on 21-inch 911 Turbo Design wheels. Its brake calipers painted in Acid Green are a typical sign of Porsche E-Performance.

The Panamera Turbo Sport Turismo is further distinguished by 20-inch Panamera Turbo wheels and brake calipers with a red finish. The power of the Panamera 4S Sport Turismo is delivered to the road by 19-inch Panamera S wheels. Behind them: brake calipers in Titanium Grey. The Panamera 4 and Panamera 4 E-Hybrid Sport Turismo are equipped with 19-inch Panamera wheels. Their brake calipers have a black anodised finish, while those of the E-Hybrid are painted in Acid Green.

Panamera Turbo Sport Turismo





The tinted glass panels of the optional panoramic sunroof¹⁾ on the new Panamera Sport Turismo models create a particularly bright and pleasant lighting mood in the interior. The two-piece panoramic sunroof can be tilted and opened electrically at the front.

1) For a provisional period up to 08/2018, all Porsche Panamera Sport Turismo models cannot be ordered without optional panoramic roof system.



More than 60 years of making sports cars. And still plenty of room for surprises.

Interior design.

The interior design leads the way to the future of the sports car – and nevertheless remains faithful to classic Porsche principles. The centre console ascends towards the front, the analogue rev counter is positioned in the middle of the instrument cluster, the dashboard is flat and conspicuously wide.

The control concept is cutting edge: Porsche Advanced Cockpit. The centre console with Direct Touch Control has a surface in glass look featuring touchsensitive buttons for direct access to the most important functions. In between: the compact gear selector. The dashboard incorporates a high-resolution 12-inch touchscreen display.

In conjunction with optional four-zone automatic climate control and individual power seats in the rear, the rear passengers also have a touchscreen display of their own. Two high-resolution screens, one to the right and one to left of the rev counter, display virtual instruments, maps and a range of other information.

Above all, though, there is plenty of space and comfort. Front and rear. Not so typical of a sports car? Absolutely typical of the Panamera model range.

New to the Panamera Sport Turismo is the seat layout in the rear compartment. The fact that four persons can appreciate a sporty yet comfortable drive in the Panamera is already old news in the automotive luxury class.

In Sport Turismo form, it now incorporates a 4+1 seating concept as standard so that a fifth person can enjoy the Panamera driving experience. Although not designed as a full-size individual seat, the extra space does provide a neat solution for carrying an additional passenger on short to medium distance trips. And, visually, it maintains the impression of a sporty four-seater – typical of the Panamera. On request, you can revert to the 'classic' four-seat configuration if you choose optional individual power seats for the rear.

Thanks to the higher roof line, passengers seated in the rear of the Sport Turismo also benefit from some extra headroom.





Panamera Turbo S E-Hybrid Sport Turismo



Panamera Turbo Sport Turismo



Panamera 4S Sport Turismo



Panamera 4 E-Hybrid Sport Turismo



Panamera 4 Sport Turismo



Drive and chassis.

In the development of a sports car, there is no reverse gear.
Except only in the gear box.

Having courage. Possible in one direction only: the future.

Engines.

“That’s the way we’ve always done it.” Not really a sentence to inspire change. Except at Porsche. That’s because we’ve always made each new generation of engines higher-performing, more dynamic and more efficient than the last.

The turbocharged V6 engine in the Panamera 4 Sport Turismo, the twin-turbo V6 engines in the Panamera 4 E-Hybrid Sport Turismo and Panamera 4S Sport Turismo, and the twin-turbo V8 engine in the Panamera Turbo Sport Turismo are equipped with VarioCam Plus: a system that adjusts the camshafts and valve lift. Their turbochargers are positioned in between the cylinder banks. This reduces the distance that the exhaust stream has to travel to reach the respective turbo – delivering a more rapid response.

The twin-turbo V8 engine of the Panamera Turbo Sport Turismo and of the Panamera Turbo S E-Hybrid Sport Turismo is equipped with twin-scroll turbines. The exhaust streams arrive at the turbine wheel through physically separate channels – for optimised gas cycles. The result: high torque even in the low rpm range.

The adaptive cylinder control of the twin-turbo V8 engine in the Panamera Turbo Sport Turismo activates cylinders on demand. An example: you’re driving in town and have little need for power, so the engine fires only on four cylinders. Once you demand greater power output again, all cylinders will immediately be reactivated.

Direct fuel injection is realised by a central injector inside the combustion chamber. This optimises both the mixture injection and the combustion – for greater efficiency and increased power delivery.

On the subject of high efficiency: all engines are purposefully equipped with electrical system recuperation, thermal management, auto start/stop with coasting function and active air intake flaps. And driving pleasure? Greater than ever.

For fuel consumption, CO₂ emissions, electricity consumption and efficiency class, please refer to page 166 onwards.



The 4.0-litre twin-turbo V8 engine in the Panamera Turbo Sport Turismo and Panamera Turbo S E-Hybrid Sport Turismo.

Delivering 404 kW (550 hp), the 4.0-litre twin-turbo V8 engine with twin-scroll turbines, VarioCam Plus and adaptive cylinder control masters the balancing act between superlative sporty performance and comparatively low fuel consumption for the segment.

In the Panamera Turbo Sport Turismo, the engine is equipped with the VarioCam Plus with adaptive cylinder control, in the Panamera Turbo S E-Hybrid Sport Turismo with the VarioCam, due to its integration in the electric motor. The maximum torque of 770 Nm is reached between 1,960 and 4,500 rpm.

For fuel consumption, CO₂ emissions, electricity consumption and efficiency class, please refer to page 166 onwards.

The 2.9-litre twin-turbo V6 engine in the Panamera 4S and Panamera 4 E-Hybrid Sport Turismo.

The 2.9-litre twin-turbo V6 engine in the Panamera 4S Sport Turismo produces a mighty 324 kW (440 hp). Maximum torque: 550 Nm at 1,750–5,500 rpm.

In the Panamera 4 E-Hybrid Sport Turismo, the combustion engine is fine-tuned to work in interaction with the electric motor, and develops 243 kW (330 hp). Find out more on page 46.

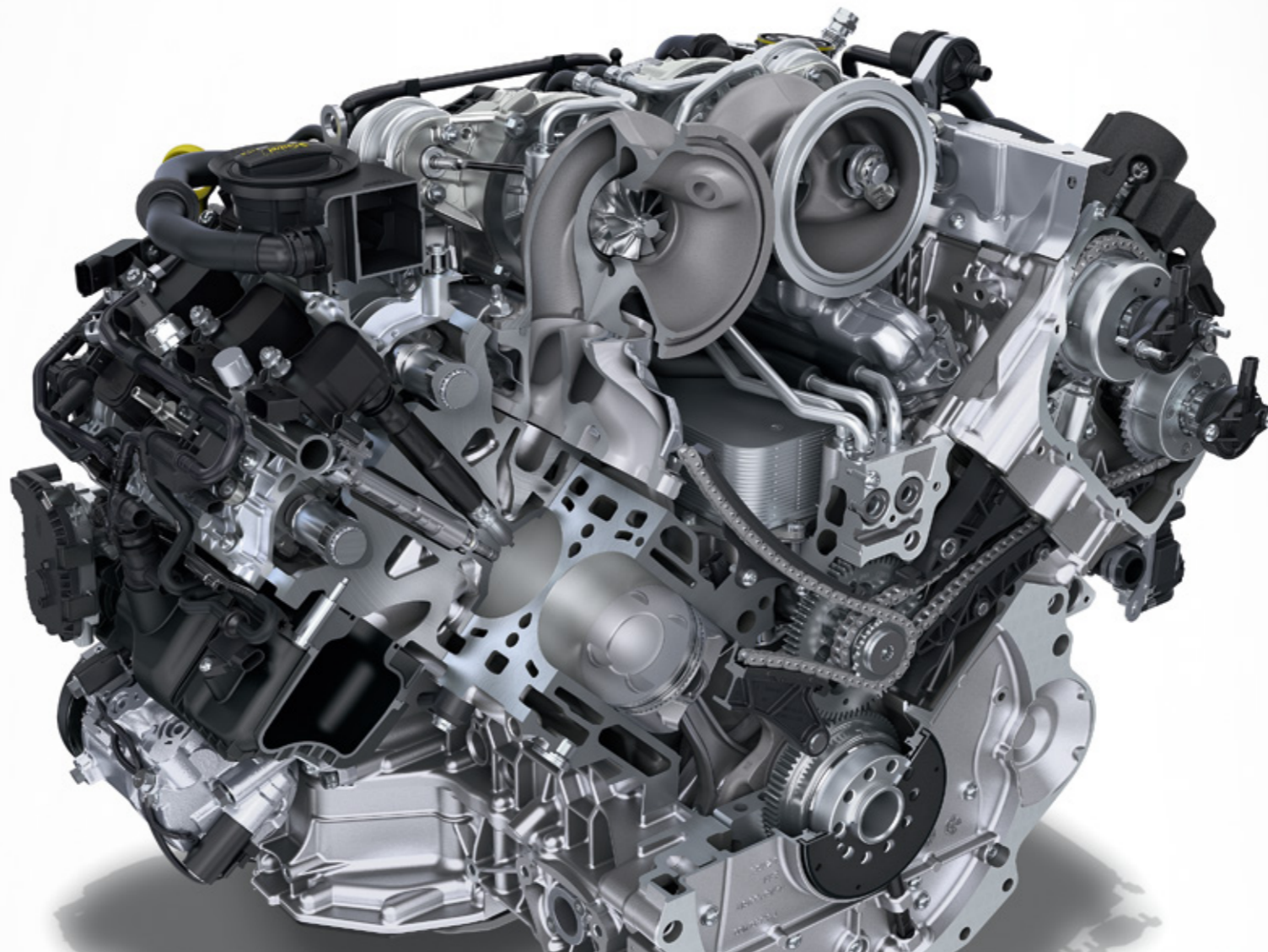

The 3.0-litre turbocharged V6 engine in the Panamera 4 Sport Turismo.

The efficient 3.0-litre V6 turbo engine in the Panamera 4 Sport Turismo is equipped with a twin-scroll turbocharger between the cylinder banks and provides 243 kW (330 hp). The maximum torque of 450 Nm is reached at 1,340–4,900 rpm.

4.0-litre twin-turbo V8 engine



It would be a pity if technologies like this remained on the track.

The new Panamera Turbo S E-Hybrid Sport Turismo.

There is a name at Porsche, where enthusiasts pause for a moment. Because they know that it is a commitment to pure performance. Because they know that a Panamera with the abbreviation Turbo S marks a performance level, which is unequalled. But this time, it is not about an even stronger engine.

The combination of the internal combustion engine and the electric machine is decisive: 2 drives that ideally complement each other. The internal combustion engine builds up power and torque with increasing speed. The maximum torque of the electric machine is immediately available. Result: The system torque of 850 Nm is already present at 1,400 rpm.

The 4.0-litre twin-turbo V8 engine with twin-scroll turbines achieves 404 kW (550 hp). The e-machine has 100 kW (136 hp), the overall system performance is an impressive 500 kW (680 hp).

The sprint from 0-100 km/h is completed in only 3.4 seconds. 200 km/h are reached after only 11.9 seconds. The top speed: 310 km/h.

Drive technology, whose roots lie in motorsports. Which was tested on the circuit. And find their way to the road in the new Panamera Turbo S E-Hybrid Sport Turismo.

For fuel consumption, CO₂ emissions, electricity consumption and efficiency class, please refer to page 166 onwards.

Courage changes the sports car of the future. And the future of the sports car.

The new Panamera 4 E-Hybrid Sport Turismo.

The Panamera 4 E-Hybrid Sport Turismo will change your perception of hybrid technology. Just as it will your everyday life. With a maximum total system power of 340 kW (462 hp). Sounds good? Read on.

Even at just 1,100 rpm, there is already 700 Nm of torque – for incomparable acceleration from a standing start and a new maximum limit for your adrenaline level.

Pure sports car performance, in other words. The figures speak for themselves: acceleration from 0 to 100 km/h in only 4.6 seconds and a top speed of 275 km/h. And that's despite a fuel consumption of just 2.6 litres/100 km.

The total system power is achieved by combining the 243 kW (330 hp) output of the 2.9-litre twin-turbo V6 engine with the 100 kW (136 hp) output of the electric machine. But a high-performance electric machine also needs a powerful energy store – and this task is handled by the 14 kWh lithium-ion high-voltage battery. As a result, the vehicle boasts an electric range of 25–51 km. And a top speed of 140 km/h on electric power alone.

The new Panamera 4 E-Hybrid Sport Turismo. A courageous next step? More like a leap. Direction: future.

For information on fuel consumption, CO₂ emissions, electricity consumption and efficiency class, please refer to page 166 onwards.

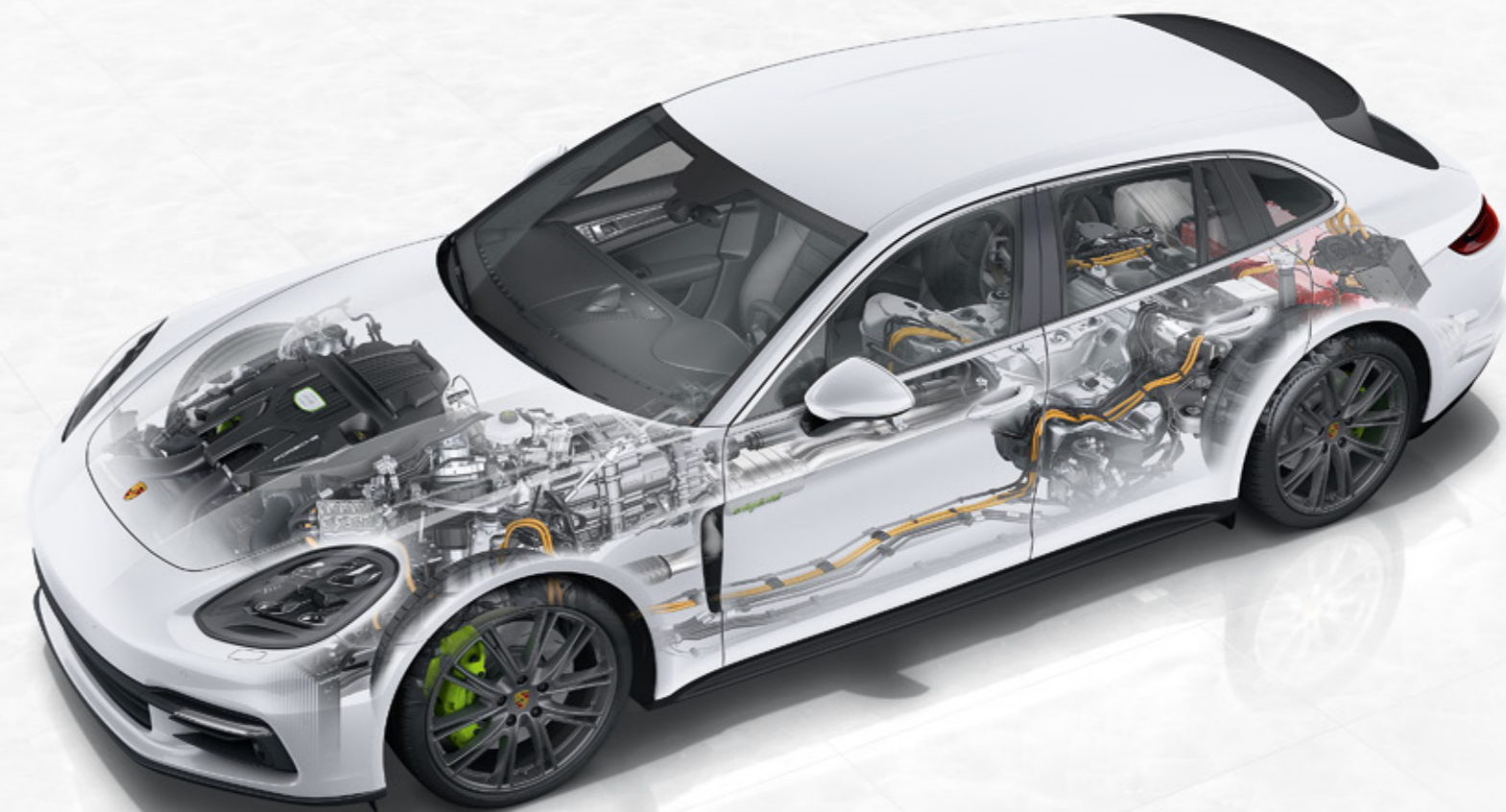

Faster. Towards the future.

Porsche E-Performance.

Six driving modes.

With Porsche Communication Management (PCM) and the mode switch on the steering wheel, derived from the 918 Spyder, you can choose from up to six driving modes – as well as the SPORT Response function for maximum responsiveness.

1. E-Power.

The vehicle runs entirely on electricity in the e-power mode. If you surpass a certain pressure point with the gas pedal, the combustion engine starts up and you can call on the full power.

2. Hybrid Auto.

The intelligent Hybrid Auto mode offers the greatest operating efficiency for trips across town and country. In this mode, the Panamera E-Hybrid is driven by the electric machine, the combustion engine or by both together as the situation demands. For the best possible combination of the two drive systems, the optimum operating strategy is derived from information relating to driving profile, state of charge, road topography and speed.

3. E-Hold.

In E-Hold mode, the state of charge of the high-voltage battery is maintained at the current level. This means that the energy of the battery can be used at a later time, e.g. for all-electric driving or boosting.

4. E-Charge.

When driving in the E-Charge mode, the high-voltage battery is charged by the internal combustion engine. You can use a section of the motorway to cover the subsequent city tour purely electrically, for example.

5. SPORT.

In SPORT mode, the combustion engine is activated by default and accelerates the Panamera E-Hybrid Sport Turismo in interaction with the electric machine. The drivetrain and chassis adopt a sporty setup (see also page 62). In addition, all the energy of the high-voltage battery is made available for boosting.

6. SPORT PLUS.

In the SPORT PLUS mode, the drive and chassis are in the performance setting. In addition, the top speed is available in the SPORT PLUS mode. With the power reserves of the combustion engine, the battery is charged – this energy can be used for boosting operations.

Display concept.

The instrument cluster's centrally located power meter shows the power currently being drawn on, as well as the boost and recovery range and informs about the vehicle's operational readiness. Hybrid screens display E-range as well as battery charge state and more.

Via the 12-inch touchscreen of the PCM, you can use Porsche Connect services, for example, the energy flow display and select between different vehicle and hybrid functions (more on page 88).



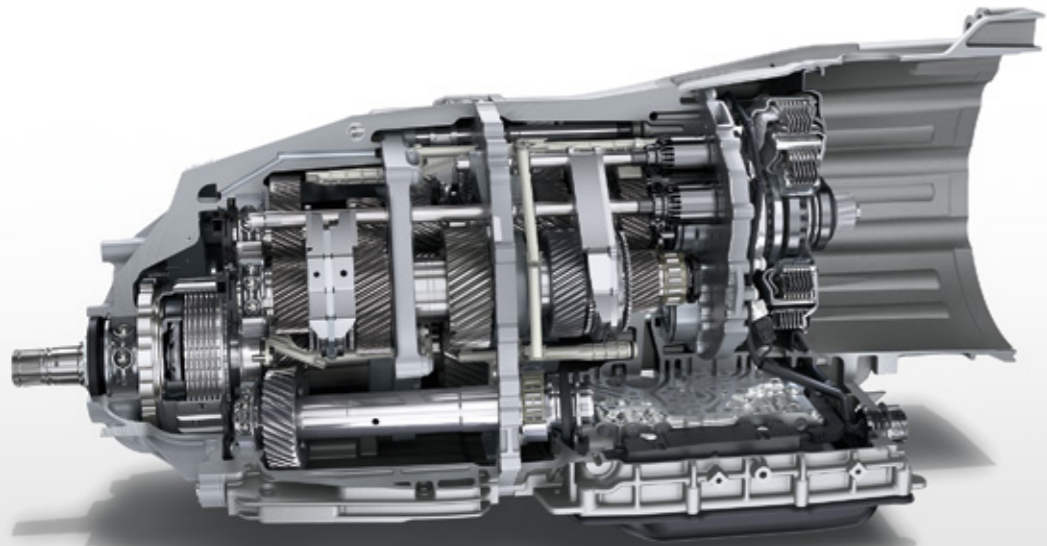

Those who want power must not only demand it, they must also pass it on.

Transmission.

New 8-speed Porsche Doppelkupplung (PDK). Getting more power from an engine is worthwhile only when you know where it needs to go. And how quickly and effectively. The new Panamera Sport Turismo models are therefore equipped with 8-speed Porsche Doppelkupplung (PDK), which translates the tremendous drive force of the respective engine into the acceleration typical of a sports car.

Gears 1 to 6 have a sports ratio and top speed is reached in 6th gear. 7th and 8th gear have a long ratio, which helps to keep engine revs low even at high speeds – for efficient and comfortable driving over long distances. The precise gearshifts take place in milliseconds with no discernible interruption in the flow of power – just as you would expect of a sports car.

1 8-speed Porsche Doppelkupplung (PDK)



**Porsche Traction Management (PTM)
all-wheel drive.**

All Panamera Sport Turismo models are equipped with Porsche Traction Management (PTM). This active all-wheel drive with electronic and map-controlled multi-plate clutch ensures the optimum distribution of drive force whatever the driving situation – for excellent acceleration power on long straights, through tight corners and on road surfaces with varying grip.

The multi-plate clutch regulates the distribution of drive force between the rear axle and the front axle. Driving conditions are constantly monitored, enabling the system to respond to a variety of situations. Sensors check, among other variables, the rotation speeds of all four wheels, the longitudinal and lateral acceleration of the vehicle, and the steering angle. If the rear wheels threaten to spin under acceleration, a greater proportion of drive force is distributed to the front by a more powerful engagement of the multi-plate clutch.



The main thing is you follow your own path. But in a consistent way.

Chassis.

Whether you're behind the wheel or occupying a passenger seat in the front or rear: in a Porsche, every drive should feel like sport, not transport. With comfort, not cosy cuddles.

The chassis of the new Panamera Sport Turismo models performs this balancing act between sport and comfort effortlessly – and in the most masterful way possible: with further-developed, optional chassis technologies. Examples include the adaptive air suspension with three-chamber technology boasting a 60 % greater air capacity than that of the predecessor, new Porsche Dynamic Chassis Control Sport (PDCC Sport) and rear-axle steering. What's also new is the integrated Porsche 4D Chassis Control system, which centrally analyses the driving situation in all three spatial dimensions, e.g. pitch, roll and yaw, computes optimum driving states from these data, and

synchronises all chassis systems in real time: the fourth dimension. The objective is to optimise overall performance, and to make the middle ground between sporty driving and comfort as expansive as possible.

Rear-axle steering.

Rear-axle steering is available for all Panamera Sport Turismo models on request. It enhances performance and everyday practicality in equal measure.

During low-speed manoeuvres, the system steers the rear wheels in the opposite direction to that of the front wheels. This has the virtual effect of shortening the wheelbase. The turning radius is reduced, agility is increased and parking becomes noticeably easier to manage.

During high-speed manoeuvres, the system steers the rear wheels in the same direction as that of the front wheels. This virtual extension of the wheelbase increases driving stability.

Rear-axle steering makes it clear that there is no contradiction between stability and agility or performance and everyday practicality. The result: greater manoeuvrability and driving safety in everyday use – and a significant increase in maximum driving performance.

Porsche Active Suspension Management (PASM).

PASM is an electronic damping control system. It actively and continuously adjusts the damping force on each wheel, based on current road conditions and driving style. The effect is to reduce vehicle body movement and thereby improve comfort.

Three modes are available: 'Normal', 'SPORT' and 'SPORT PLUS'. Sensors record the body movements as they occur during powerful acceleration, braking, fast cornering or on uneven road surfaces. From these data, the control unit of the Porsche 4D Chassis Control system determines the effect on the actual driving state of the car and modifies the damping force on each of the wheels in accordance with the selected mode. The results are tangible: increased driving stability, improved comfort and enhanced performance.

Porsche Dynamic Chassis Control Sport (PDCC Sport) including Porsche Torque Vectoring Plus (PTV Plus).

Porsche Dynamic Chassis Control Sport (PDCC Sport) is an active roll stabilisation system with an ultra sporty setup. It registers the lateral inclination of the body induced by cornering from the very outset and acts to suppress it. The system also reduces the lateral instability of the vehicle on uneven ground.

The best part of this is the active electromechanical anti-roll bars. These provide a much faster response and are tuned for sporty driving. The result: improved performance.

In combination with PDCC Sport, PTV Plus enhances driving dynamics and stability. As a function of steering angle and steering speed,

accelerator pedal position, yaw rate and vehicle speed, it improves steering response and precision by the strategic braking of the right or left rear wheel. At high speeds and under acceleration out of corners, the electronically controlled rear differential lock with fully variable torque distribution also acts to provide greater driving stability and traction.

The overall result? Strong resistance to destabilising side forces for self-assured poise. Excellent traction. Great agility at every speed – with precise turn-in and well-balanced load transfer characteristics. And, accordingly, even more fun in the corners.



Brakes.

For over 60 years, we've been working on being faster. Even when it comes to slowing down. That's why all models – except for the Panamera Turbo S E-Hybrid Sport Turismo – are equipped with a brake system having six-piston aluminium monobloc fixed brake calipers at the front and four-piston equivalents at the rear. The brake discs are internally vented and slotted. This improves braking behaviour even under extreme conditions and heat is dissipated more effectively. The one-piece brake calipers have an enclosed construction. This makes them lighter yet highly resistant to deformation. Pedal travel is tight, the pressure point precise, the braking distance impressively short.

Porsche Ceramic Composite Brake (PCCB).

Proven in motorsport, and installed as standard on the Panamera Turbo S E-Hybrid Sport Turismo, the Porsche Ceramic Composite Brake (PCCB) is

available as an option. The cross-drilled ceramic brake discs of PCCB have a diameter of 420 mm at the front and 410 mm at the rear – for even more formidable braking performance. PCCB features 10-piston aluminium monobloc fixed brake calipers on the front axle and four-piston units at the rear – all painted in yellow – to provide braking forces that are considerably more powerful and, crucially, are exceptionally consistent. PCCB enables shorter braking distances in even the toughest road and race conditions. Safety under high-speed braking is also improved thanks to its excellent fade resistance. Another advantage of PCCB is the extremely low weight of the ceramic brake discs. This results in better roadholding and increased comfort, particularly on uneven roads, as well as greater agility and a further improvement in handling.

Panamera Turbo S E-Hybrid Sport Turismo with Porsche Ceramic Composite Brake (PCCB) with brake calipers in Acid Green





1



2



3



4



5



6



7

Wheels.

We rise to the challenge we're given. The same applies to the wheel dimensions of the new Panamera Sport Turismo. The tyres are wide, the contact patch is large – for enhanced performance under acceleration and braking. The Panamera 4 and 4S Sport Turismo models are equipped as

standard with 19-inch wheels, the Panamera Turbo Sport Turismo with 20-inch wheels, the Panamera Turbo S E-Hybrid Sport Turismo comes on 21-inch 911 Turbo Design wheels. The material? Light alloy, of course. The design? Classic and sporty. A choice of other 19-, 20- and 21-inch wheels is available on request.

- 1 21-inch 911 Turbo Design wheel
- 2 21-inch Exclusive Design wheel painted in black (high-gloss)
- 3 21-inch Panamera SportDesign wheel
- 4 20-inch Panamera Design wheel
- 5 20-inch Panamera Turbo wheel
- 6 19-inch Panamera S wheel
- 7 19-inch Panamera wheel

SPORT mode.

With SPORT mode, you can swap from a comfort-oriented tuning to a sporty setup. The electronic engine management system demands a sharper response. Engine dynamics become more direct. In SPORT mode, PDK shifts up later and shifts down sooner. Porsche Active Suspension Management (PASM) and optional Porsche Dynamic Chassis Control Sport (PDCC Sport) and rear-axle steering also switch to SPORT mode, delivering harder damping and more direct turn-in – and even greater agility through corners.

Sport Chrono Package including mode switch.

Adrenaline at the push of a button: the Sport Chrono Package offers an even sportier tuning of the chassis, engine and transmission. The kit includes a digital and analogue stopwatch, a graphic in the instrument cluster showing longitudinal and lateral acceleration, and a performance display for viewing lap times in Porsche Communication Management (PCM).

The mode switch on the steering wheel with SPORT Response button has been derived from the 918 Spyder. Four driving modes are available to choose from: 'Normal', 'SPORT', 'SPORT PLUS' and 'Individual' – for an even more personalised driving style.

In the Panamera 4 E-Hybrid Sport Turismo and the Panamera Turbo S E-Hybrid Sport Turismo, the Sport Chrono Package is included as standard. Unlike in models powered by combustion engine alone, it has been specially tuned for E-Performance (see page 48). Using the hybrid-specific mode switch, you can select the modes 'E-Power', 'Hybrid Auto', 'SPORT' and 'SPORT PLUS', while 'E-Hold', 'E-Charge' and 'Individual' are accessible from Porsche Communication Management (PCM).





In SPORT mode alone, the new Panamera Sport Turismo delivers increased dynamics and more direct handling (see page 62). In SPORT PLUS mode, the engine becomes even more responsive. The rev limiter is adjusted to a harder setting. Porsche Active Suspension Management (PASM) and Porsche Dynamic Chassis Control Sport (PDCC Sport) are retuned for harder damping and more direct turn-in. The adaptive air suspension drops to Low Level and firms the spring rate. The rear-axle steering acts to provide even greater agility. Another function included in the package is Launch Control – for optimum acceleration from a standing start.

The stopwatch mounted on the dashboard displays recorded driving time or can be used as a conventional clock. Porsche Communication Management (PCM) is upgraded to include a performance display, enabling you to view, store and evaluate laps or other driving times.

SPORT Response.

Pressing the button in the centre of the mode switch primes the engine and transmission for the fastest possible unleashing of power (e.g. for overtaking).

In other words, maximum responsiveness – for a period of approximately 20 seconds.

PSM Sport.

In conjunction with the Sport Chrono Package, Porsche Stability Management (PSM) is supplemented by a 'Sport' mode. It allows a significantly more sporty driving style, with PSM remaining active in the background. For a further enhancement to your driving experience.

**For others, it's the order of the hour.
For us, it's been the order since the first second.**

Porsche and the environment.

In an era of global climate change, every automotive manufacturer is asking what it has to offer right now. Our answer? Excellent performance together with excellent efficiency.

Hybrid technology.

Everyone is talking about electric mobility. There is a collective drive to find answers to one of the greatest challenges of our time: how to conserve resources, and how to cut energy requirements and CO₂ emissions. With Porsche E-Performance, we provide our answers. Not some time in the future, but right here and now. Fuel consumption and CO₂ emissions have to be reduced globally. We believe that, as a sports car manufacturer, we should start where we can actually change something: in the everyday life of our drivers – with an intelligent total concept. So it's no wonder that – for us – Porsche E-Performance is more than just a drive concept alone.

Fuel economy and recycling.

Vehicles manufactured by Porsche demonstrate that even high-performance sports cars can achieve moderate fuel consumption and exhaust emission values in their respective category. This is accomplished, on the one hand, with the efficient use of fuel by means of efficiency-enhancing technologies such as auto start/stop, thermal management, electrical system recuperation, adaptive cylinder control and coasting. On the other hand, catalytic converters with stereo Lambda control circuits provide efficient emission control.

Intelligent lightweight construction is integral to the Porsche identity. This identity is expressed in the form of a high proportion of aluminium, magnesium, plastics and super-high-strength sheet steels. All materials have been strategically selected, and the paints used are predominantly environmentally friendly water-based paints. Each lightweight material is easily recyclable and all

plastic components are labelled to facilitate future separation for recycling.

Fuel.

All petrol-engined Porsche models – including those in the Panamera range – are designed to operate on fuels with an ethanol content of up to 10 %, e.g. 'E10'. Ethanol has a positive impact on the CO₂ balance because it is derived from plants that absorb CO₂ from the atmosphere.





Comfort and infotainment.

The best way to relax: hold on tight.



Our most important life experiences do not come from the conference room.

Interior.

Sporty, heading into a long weekend. Comfortable, for a long journey in a party of four. To the beach as five. Or perhaps an outing on the racetrack? That's the new Panamera Sport Turismo. Its ingenious sports car ergonomics are centred on the driver and on performance – without disregard for the wellbeing of passengers.

Let's give you some examples. Ascending centre console for swift hand movements from the steering wheel to the gear selector. New kind of control and display concept: Porsche Advanced Cockpit with newly styled centre console in glass look and touch-sensitive buttons arranged in logical groups. High-resolution 12-inch touchscreen display. Instrument cluster with analogue rev counter positioned in the middle, flanked on the left and right by a high-resolution display.

Multifunction sports steering wheel. And what else? You decide: seat variants, leather or two-tone interior schemes? Fine woods, aluminium or carbon? More sporty? More luxurious? Both? Thanks to our extensive range of personalisation options, the possibilities for you and your wishes are virtually boundless. Details of colours and personalisation options can be found on page 106 onwards.

The new Porsche Rear Seat Entertainment.

A cinematic experience enjoyed in the second row: new Porsche Rear Seat Entertainment has been specially developed to appeal to the discerning taste of a Porsche passenger and offers a fully integrated and networked infotainment system for on the move. Both units are removable, making them convenient to use outside the vehicle, too.

Porsche Rear Seat Entertainment connects to Porsche Communication Management (PCM) via WiFi to provide access to the radio, media, navigation system and vehicle functions of your Panamera Sport Turismo. A wealth of entertainment awaits, thanks to two separate 10-inch touchscreen

displays on the front seat backrests, an internal 32 GB memory, micro SD card slot, micro USB interface, Bluetooth® and NFC (near field communication). Through the connection to the WLAN router of the Connect Plus module (see page 91), you also gain access to the Internet and up to one million apps and games, to movies and music, audiobooks, e-books and productivity applications from the GOOGLE® Play Store.

For an unrestricted listening experience, the sound can be output from the integrated loudspeakers, the in-car sound system or the wireless Bluetooth® headphones.





The best thing about the future? It's right before us.

Instrument cluster.

Analogue meets digital: the instrument cluster of the new Panamera Sport Turismo models is reminiscent of Porsche motorsport history – and nevertheless ultra-modern.

In the middle and in direct view of the driver is the analogue rev counter, its needle integral to its truly classic design. To the left and right, two high-resolution displays provide you with a variety of information as and when you need it, such as the navigation map or Night Vision Assist.

On the left-hand side of the rev counter is the speedometer. In its centre, you can see data relating to adaptive cruise control, for example.

In the display field on the outside left, you can choose to show the speed limit indicator, traffic sign recognition or the outside temperature.

On the right-hand side, the possibilities are even more varied. The inside display field is occupied by information from the on-board computer, the fuel gauge or range remaining. In the field on the outside right, you can see the time. And there's also the option of viewing the map of the navigation system.

Ambient lighting.

Ambient lighting is available on request: an indirect lighting concept designed to enhance passenger comfort. You can choose from seven lighting colours and customise their intensity.





Front seats.

The front seats offer a high level of comfort and provide support in fast corners without restricting freedom of movement. The seat height, squab and backrest angles and fore/aft position are electrically adjustable.

Power seats.

The Panamera Turbo Sport Turismo and the Panamera Turbo S E-Hybrid Sport Turismo are equipped with 14-way power seats including memory package in the front. These add seat squab length adjustment and four-way lumbar support for the driver and front passenger. The memory function stores settings for seats, steering column, both exterior mirrors and other personalised in-car settings.

Adaptive Sports seats.

The Panamera Turbo Sport Turismo is equipped with 18-way power seats including memory package in the front. These add seat squab length adjustment and four-way lumbar support for the driver and front passenger. The memory function stores settings for seats, steering column, both exterior mirrors and other personalised in-car settings. Electrically adjustable, they offer comfort on long journeys and made-to-measure lateral support in the corners.

Rear seats.

Thanks to the new 2+1 seating concept, the rear compartment can accommodate up to three passengers as standard (see also page 26). Still designed as full-fledged individual seats, the two outer seats in the back offer plenty of leg- and headroom and excellent lateral support through fast corners without sacrificing comfort. The four-seat configuration is still available on request with optional individual power seats for the rear.

Seat heating and ventilation.

The front seats of the new Panamera 4S Sport Turismo – and the rear seats of the Panamera Turbo and Panamera Turbo S E-Hybrid – come equipped with seat heating to warm the squab and backrest to an agreeable temperature. Optional seat ventilation incorporates active aeration of the perforated seat centre and backrest to provide a pleasant seating environment – even in hot weather.

Massage function.

On request, the power seats are also available with a massage function – front and rear. With five programmes and five intensity levels to choose from, 10 air cushions in each backrest provide a relaxing treat for the back muscles. For improved seating and long-distance comfort.

-
- 1 Power seats in front and individual power seats in rear
 - 2 Adaptive Sports seats in front and individual power seats in rear

And what are you up to today?

Luggage compartment.

The luggage compartment of the Panamera Sport Turismo models offers a capacity of 520 litres (Panamera 4 E-Hybrid Sport Turismo and Panamera Turbo S E-Hybrid Sport Turismo: 425 litres). In all models, the rear seats can be folded down as one or separately in the ratio 40 : 20 : 40 by remote power release from the luggage compartment or manually from the passenger compartment. The cargo position gives you a load capacity of up to 1,390 litres (1,295 litres in the Panamera 4 E-Hybrid Sport Turismo and Panamera Turbo S E-Hybrid Sport Turismo). In a sports car, in case we should forget.

On all Panamera Sport Turismo models, the loading edge is comparatively low at 628 mm, which makes it easier to load bulky items in particular. The especially large automatic rear hatch with customisable opening angle is fitted as standard to all models. It closes conveniently at the push of a button.

The loadspace management system is available on request. This versatile solution for the secure transport of items in the luggage compartment includes two attachment rails integrated into the luggage compartment floor, four lashing eyelets, a luggage compartment partition net and more. Using the optional 230-V socket in the luggage compartment, it is possible to power devices rated up to 150 W that do not have a 12-V connection.

Travelling light or got plenty of gear? Need your sports kit? A shopping spree for everyone? The new Panamera Sport Turismo – so much is certain – finds plenty of ways to answer questions.





Four-zone automatic climate control.

Welcome to your personal climate zone. Four-zone automatic climate control features individual temperature setting controls for the driver and front passenger, and separate ones for the rear seats, too.

In conjunction with optional individual power seats in the rear, four-zone automatic climate control comes with an additional touchscreen display in the rear compartment for controlling an array of comfort and infotainment functions.

An active carbon filter traps particles, pollen and odours and thoroughly filters fine dust out of the outside air before it can reach the interior.

A new ionisation function is available as an option – for improved air stream quality. Before it reaches the cabin, the air in the automatic climate control system is passed through an ioniser. Airborne germs and pollutants are reduced and the interior air is appreciably refreshed for an even more pleasant cabin environment.

We love to break barriers. Sonic ones included.

Sound systems.

BOSE® Surround Sound System.

The BOSE® Surround Sound System features 14 amplifier channels and offers a total output of 710 watts. 14 loudspeakers including a 160-watt passive subwoofer box ensure a balanced, faithfully reproduced acoustic pattern. The patented AudioPilot® Noise Compensation Technology continuously measures the ambient noise inside the vehicle and adapts music playback instantly

and automatically so that a consistent sound is maintained – whatever the driving conditions. The result is a captivating 360° acoustic experience delivered to all seat positions. At all times.



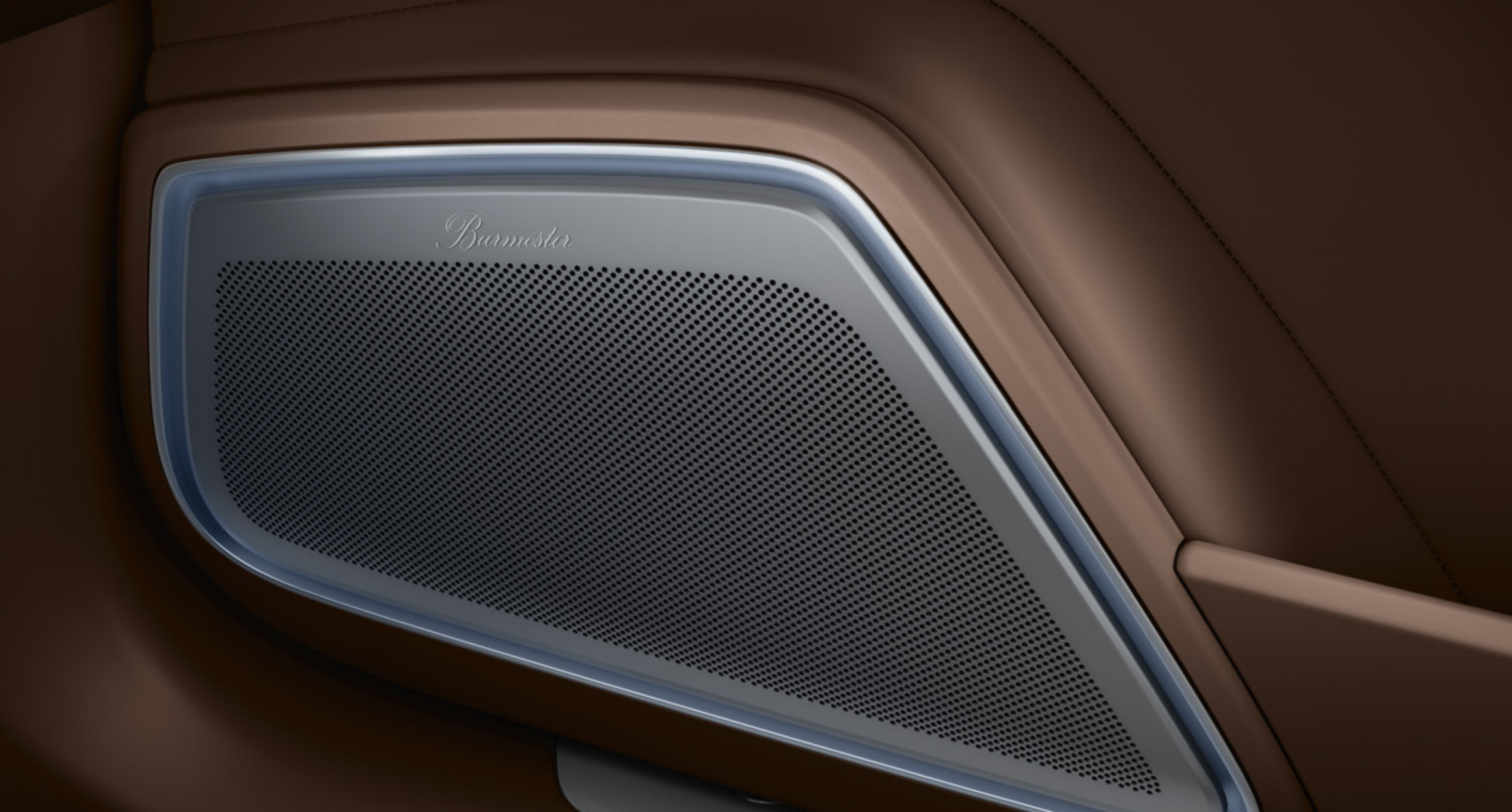

Burmester® High-End 3D Surround Sound System. 'Concert hall for the road?' Panamera Sport Turismo. The Burmester® High-End 3D Surround Sound System delivers an acoustic performance worthy of one of the best concert halls in the world. Every audience member can enjoy the full breadth of the stage, thanks to the perceived spatial distribution of the sound source.

Quiet, please, as we introduce a total output of 1,455 watts, 21 individually controlled loudspeakers including an active subwoofer with 400-watt class D digital amplifier, two-way centre system and a total diaphragm surface area of more than 2,500 cm². Air motion transformer (AMT) tweeters have been used for unmistakably fine, clear and undistorted high-frequency sound reproduction with excellent level stability.

All loudspeaker housings are perfectly matched and deliver superior bass foundation, definition and impulse accuracy. The result is a natural and richly textured spatial sound, even at top volume. Particularly impressive is the new 3D sound experience, created by the loudspeakers integrated into the roof pillars and by the use of a special 3D algorithm.

A superlative visual performance, too. The borders of the loudspeaker trims are illuminated in white or – in conjunction with optional ambient lighting – a choice of seven colours. Uncompromising in sound and design.

Get more day out of your everyday.

Porsche Connect.

Porsche Connect enhances existing vehicle functions with intelligent services and apps – all of which are intended to make the connection between car and driver even more intimate, to intensify that Porsche fascination, and to make the challenges of everyday life quick and easy to overcome.

Porsche Communication Management (PCM) including online navigation.

PCM is your control centre for audio, navigation and communication functions. In its latest generation with mobile phone preparation, audio interfaces and voice control system, it also features a highresolution 12-inch touchscreen display enabling easy control of the majority of in-car functions.

On the move, you can enjoy your favourite music from a variety of sources, including CD/DVD drive, SD cards, internal 10-GB hard drive (jukebox), AUX input or the USB connection, e.g. for connecting your iPhone®. Or you can simply listen to the radio.





Connect Plus¹⁾.

The Connect Plus module implements connectivity in your Porsche.

With it, you can integrate your smartphone optimally into your vehicle. A smartphone compartment in the centre console transfers the signal of your mobile phone to the external aerial of the car – conserving phone charge and providing optimum reception. Another feature is the LTE telephone module with SIM card reader for convenience, excellent reception and optimised voice quality.

What's more, the Connect Plus module enables use of the wide range of Porsche Connect services.

Get more day out of your everyday and delegate the multitasking to your Panamera Sport Turismo – so you can spend more time driving your Porsche.

Porsche Connect services.

The Connect Plus module gives you access to a range of helpful services, which are bundled into three dedicated packages: Navigation and Infotainment Services, Connect App Services and Car Connect Services. These include, for example, the real-time traffic information feature. With this aid, you can be sure that you're on the fastest route to your destination even before you set off. Throughout the journey, the real-time traffic information is regularly updated – keeping you on the optimum route. To let you use Porsche

Connect services, the car comes with an integrated SIM card including data allowance for the first time. Now you no longer need to provide a SIM card of your own. For use of the WiFi hotspot and music streaming functions, a WiFi data package is available from the Porsche Connect Store. Of course, you can still use your own SIM card if you prefer. Please bear in mind that this will require a valid subscription to a mobile network provider of your choice (subject to charge).

- 1 Porsche Connect Plus service parking spaces
- 2 Porsche Connect Plus display smartphone calendar in the PCM

1) Porsche Connect services (including Car Connect Services, but excluding Safety and Security Services) include an initial free subscription period, the length of which may vary by services package and country but shall not be less than three months. The full range of Porsche Connect services or individual services thereof may not be available in some countries. In addition, an LTE-capable, integrated SIM card with data allowance for use of selected Porsche Connect services will be included in the price in some countries. For use of the WiFi hotspot and the other non-included Porsche Connect services, e.g. music streaming, via integrated SIM card in these countries, a chargeable WiFi data package is also available from the Porsche Connect Store. Alternatively, you can establish a data connection using a SIM card of your own. For further information on free subscription periods, follow-on costs and availability of individual services in your country, please visit www.porsche.com/connect or consult your Porsche Centre.

Connect apps.

In addition to its range of smart services, Porsche Connect offers two smartphone apps. The first, Porsche Car Connect, lets you use your smartphone or Apple Watch® to retrieve vehicle data and remotely control selected vehicle functions. Another feature is the Porsche Vehicle Tracking System (PVTs) including theft detection.

The second app is the Porsche Connect app. This allows you to send chosen destinations to your Porsche before you start your journey. As soon as your smartphone has connected to PCM, you will be able to display them in the vehicle and start route guidance directly. Even your smartphone calendar can be viewed directly on PCM and stored addresses used for navigation. What's more, the Porsche Connect app gives you access to millions of music tracks thanks to its builtin music streaming function.

Go to www.porsche.com/connect to find out more about the apps and services available.

Apple® CarPlay.

Apple® CarPlay enables you to connect your iPhone® to your Porsche and have certain apps shown directly on the screen of Porsche Communication Management (PCM). With the Siri® voice recognition interface, you can conveniently use your apps on the move while keeping your full concentration on the road.

Porsche Connect Portal.

Every Porsche can be configured to your preference. Porsche Connect is the same. In the Porsche Connect Portal, you can manage your Porsche and personalise your Connect services to suit your interests – whether it's by adding new destinations for your navigation system or selecting your favourite sources for the news articles that you want to have read aloud in the car. The Porsche Connect Portal also lets you create additional users – such as family members or friends.

Porsche Connect Store.

Would you like to extend your initial free subscription period? Or purchase extra Porsche Connect services? Visit the Porsche Connect Store at www.porsche.com/connect-store and discover more about what Porsche Connect has to offer.



The courageous always did look far ahead.

Lights and vision.

The better way to reach your destination is by knowing what's up ahead. When driving, that's true more than ever. All Panamera Sport Turismo models are therefore equipped with LED main headlights. Distinctly Porsche: four-point daytime running lights, four-point brake lights and 3D taillights with characteristic light strip.

LED main headlights including Porsche Dynamic Light System (PDLS).

Fitted as standard to the Panamera Turbo Sport Turismo and the Turbo S E-Hybrid Sport Turismo, available as an option for all the other models: LED main headlights including Porsche Dynamic Light System (PDLS) with dynamic range adjustment, dynamic cornering lights and speed sensitive headlight range control. For enhanced near-field, lateral and far-field illumination – and added safety.

LED main headlights with matrix beam including Porsche Dynamic Light System Plus (PDLS Plus). Even greater foresight is achieved with LED main headlights featuring matrix-beam technology. The matrix-beam main headlight unit strategically deactivates specific segments of the permanent mainbeam cone. Eighty-four individually controlled LEDs adapt to the situation ahead by switching off or dimming accordingly. Vehicles in front or in the oncoming lane are no longer dazzled, while the areas in between and to the side continue to receive full illumination. To optimise target fixation, not only are the lights selectively dimmed to fade out oncoming vehicles, the area to the right of the light void is lit more brightly for better guidance of the driver's visual attention. What's more, segment-specific dimming of highly reflective traffic signs also acts to avoid driver dazzle. LED main headlights with matrix beam including PDLS Plus: bright, homogeneous, safe.

PDLS Plus, which includes all the functions of PDLS, now comes for the first time with electronic

cornering lights and an intersection light based on navigation data. As you approach a crossroads or T junction, the intersection light function activates the left and right cornering lights, and the light cone becomes wider and shorter – for enhanced illumination of your surroundings.

Night Vision Assist.

Night Vision Assist provides the driver with information even beyond the range of the headlights. An infrared camera detects pedestrians or large wildlife before they are illuminated by the headlights. A thermal image in the instrument cluster warns the driver: the detected person or animal is highlighted in yellow – or in red and accompanied by an audible signal if within the critical range in front of the vehicle. In combination with PDLS Plus, the marker light function briefly flashes the headlight at the pedestrian on the kerbside or in the carriageway three times to alert the driver's attention.

LED main headlights with matrix beam including Porsche Dynamic Light System Plus (PDLS Plus)

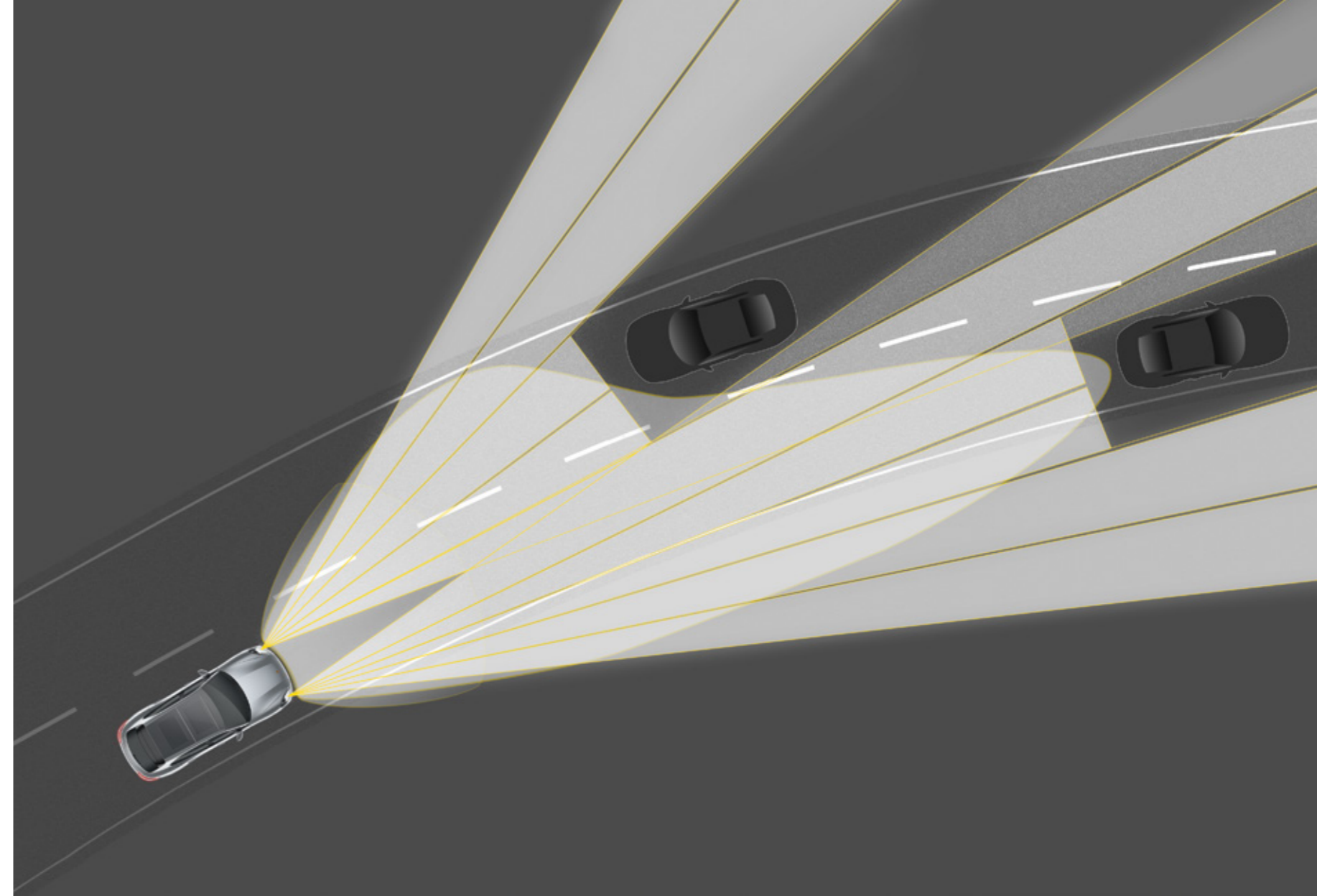



Even in leading positions, it's nice to know you don't have to do everything on your own.

Assistance systems.

It's a little bit like in your job: an assistant may relieve you of the burden – but not the pleasure. With Porsche assistance systems, it's exactly the same. Geared towards sporty, active driving, they afford you the driving pleasure you expect of a Porsche.

Adaptive cruise control (ACC).

This system regulates the speed of your Panamera Sport Turismo fully independently in line with the speed of the vehicle in front. Radar sensors inside the front end scan the road ahead. Let's imagine you've selected a cruising speed but have begun to gain on the vehicle in front because it is driving more slowly – the system reduces the speed of your vehicle by restricting throttle or gently applying the brakes until your chosen distance from the vehicle in front is restored.

Your Panamera Sport Turismo now continues to maintain this distance from the vehicle ahead. If it brakes even more, adaptive cruise control will reduce your speed accordingly – even down to a halt. As soon as the road ahead clears, your vehicle will accelerate back up to the cruising speed originally set.

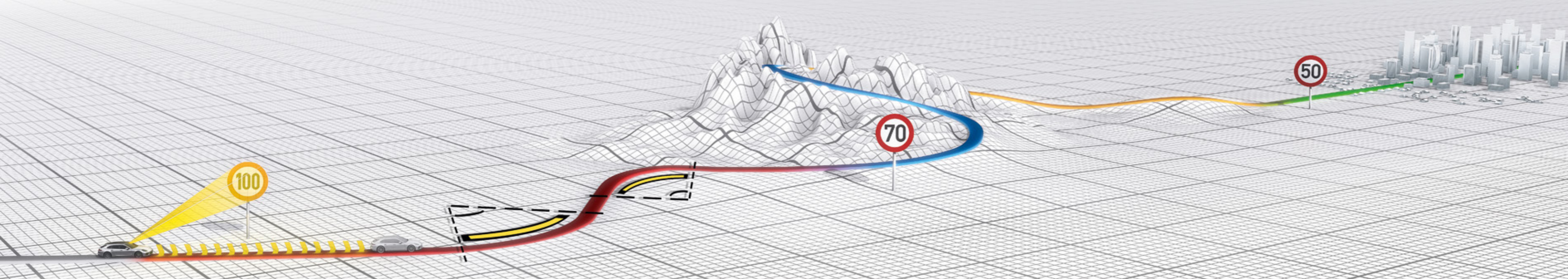

Porsche InnoDrive including adaptive cruise control.¹⁾

Those who drive a Porsche want to drive. The more sporty, more comfortable, more efficient and more safe the drive the better. Porsche InnoDrive assists you in a completely new way.

The system enhances adaptive cruise control with additional, innovative functions.

It predictively optimises your speed. With the aid of high-resolution navigation data and information supplied by the radar and video sensors, Porsche InnoDrive ascertains speed limits and topographical road features, such as gradients or corner radii, along your route even before you reach them – and modifies the gearshift strategy and speed of the Panamera Sport Turismo accordingly. For intelligent driving and a significant efficiency advantage.

You can adapt the driving feel by pressing the SPORT button. Depending on the mode, the system selects the optimum parameters for engine management and gear selection, including coasting and deceleration.

The system uses the knowledge gained from its prediction horizon of up to 3 km to formulate the optimum timing for acceleration, constant speed driving and deceleration phases to provide a harmonious driving experience.

Imagine, for example, that a speed restriction is in force further along the route but the traffic sign is not yet in sight of the driver: the system already knows that deceleration will be required and initiates a fuel-saving coasting manoeuvre.

Porsche InnoDrive represents the typically Porsche realisation of efficient driving – for greater comfort and greater driving pleasure.

Traffic Jam Assist.

Another feature of Porsche InnoDrive including adaptive cruise control is Traffic Jam Assist. It eases the burden on the driver when congestion is encountered on major inter-urban roads and motorways.

At speeds of up to approximately 60 km/h, the system uses gentle steering inputs to keep the vehicle in the middle of the lane, regulates the

distance from vehicles in front and follows the queue ahead where system limitations allow. To do this, Traffic Jam Assist tracks roadway markings and other vehicles on the carriageway. The benefit? Appreciable stress relief and greater comfort on long journeys.

¹⁾ The assistance provided by Porsche InnoDrive is subject to system limitations. The driver must monitor driving style at all times and intervene in cases of doubt. The system can be overridden at any time by use of the brake or accelerator pedal. Porsche InnoDrive is not available in some countries.



Lane Change Assist with Turn Assist.

Lane Change Assist uses radar sensors to monitor the areas to the rear of the vehicle and the blind spots on either side. As you move to change lane, the system issues a visual warning signal in the exterior mirrors if another vehicle is rapidly approaching your vehicle from behind or is residing in one of your blind spots. The function can be activated in PCM as required. For greater comfort and safety, especially on the motorway.

During low-speed turns, new Turn Assist improves safety at the rear. Once you've arrived at an intersection, Turn Assist issues a visual warning if it detects objects approaching in the blind spots behind your vehicle.

Lane Change Assist including traffic sign recognition and Turn Assist

Lane Keeping Assist including traffic sign recognition and cornering notification.

Lane Keeping Assist is a camera-based system for automatic detection of divider line markings on the road. The system eases the burden on the driver by providing steering assistance, helping to keep the vehicle in lane.

Integrated traffic sign recognition uses a camera and navigation data to detect speed limits and 'no overtaking' zones and to infer local traffic codes (e.g. from boundary signs). Information is displayed in the instrument cluster. The advantage over information stored in the navigation database is that even temporary speed restrictions can be detected.

New for Porsche is the cornering notification, an enhancement to the traffic sign recognition function. Based on navigation system data and camera recognition of cornering road signs, the system displays an arrowed direction warning on the instrument cluster display alerting you to tight corners. Long before you reach them.

How do you benefit? Increased comfort. And reduced stress, not least on long cross-country journeys.

ParkAssist including reversing camera and Surround View.

ParkAssist is fitted in all Panamera Sport Turismo models and audibly alerts the driver to the presence of obstacles detected to the front and rear of the vehicle. The audible alert is supplemented by a visual warning on the central display screen.

The optional reversing camera facilitates precise reverse parking and manoeuvring and also assists in hitching a trailer. Help is provided in the form of the camera image and the dynamic, superimposed guidelines on the PCM screen, which illustrate the predicted course of the vehicle given the current position of the steering wheel. To keep the lens clean, the reversing camera is equipped with its own washer nozzle.

The optionally available Surround View system supplements the reversing camera with three more high-resolution cameras – one in the front apron and one in each lower trim of the exterior mirrors. Based on the information supplied by all four cameras, the system generates a virtual bird's eye view of the car and displays it on the PCM screen. It is also possible to switch between various camera views to improve visibility, e.g. at narrow exits.

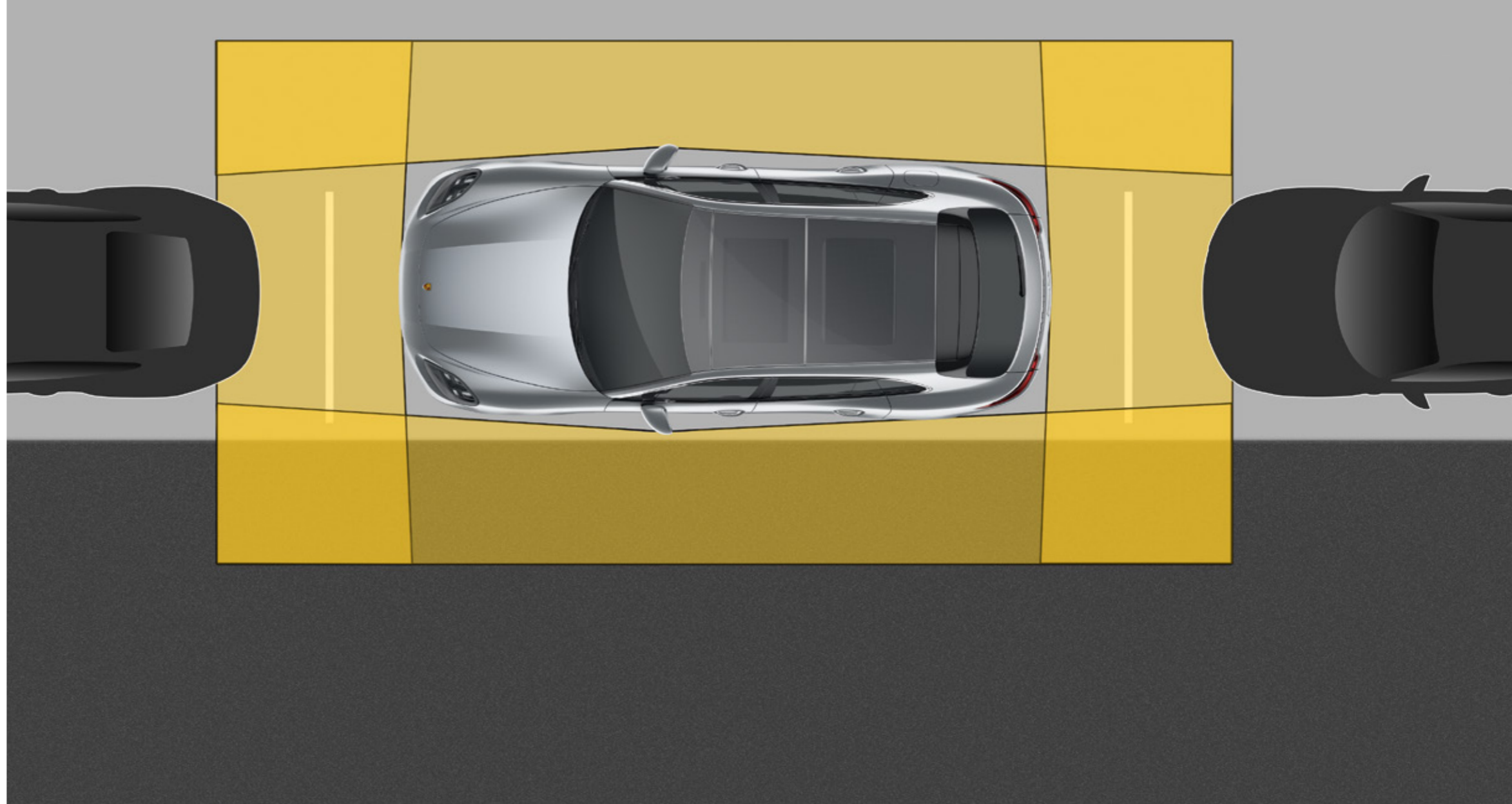



Summary.

Success is not a destination,
but one stage of a fascinating journey.



Personalisation.

Isn't it nice when life adapts to you for a change?

We believe in passion for the sports car. And for every detail.

Personalisation.

Just imagine if everything were possible. If you could create the sports car of your dreams. Without restriction. With a diverse range of colours. With extra personality and performance. Like Ferry Porsche did all that time ago with the first ever Porsche: the 356 No. 1.

On the pages that follow, we will show you how a dream car becomes a reality. For a clear overview, all available options have been organised by category. With the extensive colour palette and wide range of optional equipment, you can lend personality to your Panamera Sport Turismo. Let the following pages fill you with inspiration – and let your creativity run wild.

The possibilities are many. The limits are few and far between. Take Porsche Exclusive Manufaktur as an example, where you can have your Panamera Sport Turismo personalised even more comprehensively and entirely the way you envisaged. Directly on the shop floor. To the ultimate level. And for the most part by hand.

You can find out more about the ultimate form of personalisation on the following pages. By the way, we've taken special care to point out all the personalisation options available from Porsche Exclusive Manufaktur. You'll be amazed at what we can do.





Your inspiration. Our passion.

Porsche Exclusive Manufaktur.

Our wealth of experience goes back a long way. Since the very beginning, we at Porsche have been dedicated to realising customer wishes. Known until 1986 as the Porsche 'Sonderwunschprogramm', then Porsche Exclusive – and today we call it 'Porsche Exclusive Manufaktur'.

We love what we do. We love our work. Every seam, every square inch of leather, and every single other fine detail receives the same devotion. It's how we bring experience and passion onto the car together with inspiration – it's how we bring dreams to life. Directly from the Manufaktur.

None of this would be possible without originality, enthusiasm and attention to detail, beginning as early as the consultation stage. That's because we keep in mind one thing above all else: to fulfil your individual wishes and requirements and thus make 'a Porsche' to 'your Porsche'.

How do we fulfil these wishes? With composure and meticulous care, by means of precision handcrafting and the use of exquisite materials such as leather, fine wood or aluminium. That is how a product is created from dedication and craftsmanship. Or in other words: the intersection of sportiness, comfort, design and your personal taste. A Porsche with your characteristics.

We offer a wide range of personalisation options, with visual and technical enhancements for the interior and exterior, from a single alteration to extensive modifications. Your inspiration is our passion.

Be inspired by our example showcased on the next page and visit www.porsche.com/exclusive-manufaktur to discover everything you need to know about how to configure one of your very own.

A configuration example from the Porsche Exclusive Manufaktur.

- 1 Rev counter instrument dial in white
- 2 SportDesign package painted in black (high-gloss), sports exhaust system including sports tailpipes in black, tinted LED taillights including light strip, model designation painted
- 3 Porsche Rear Seat Entertainment
- 4 Seat centres in contrasting colour (black), Porsche Crest on headrests, seat belt in Crayon
- 5 SportDesign package painted in black (high-gloss), 21-inch Panamera SportDesign wheels painted in black (high-gloss), door handles painted in black (high-gloss), exterior mirrors painted, air diffuser painted in black (high-gloss), tinted LED main headlights with matrix beam including PDLS Plus



The fastest way out of normality? Imagination.

**Panamera Turbo S E-Hybrid Sport Turismo
in Amethyst Metallic.**



A conformist vehicle does not suit a non-conformist life.

Panamera Turbo Sport Turismo in Volcano Grey Metallic.

1



2

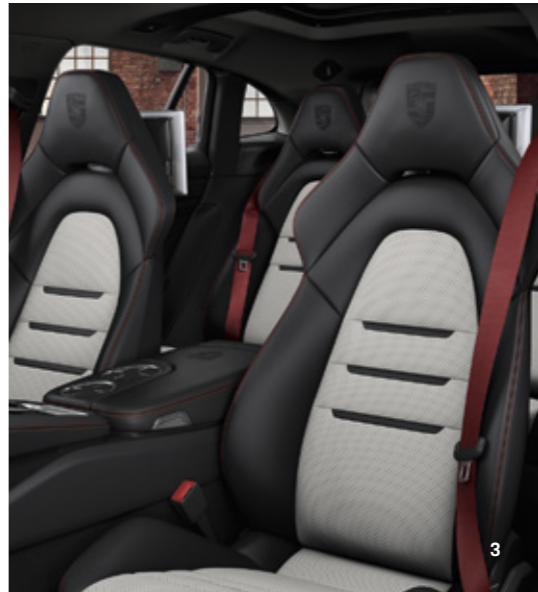

3



4

A configuration example from Porsche Exclusive Manufaktur.

- 1 21-inch Panamera SportDesign wheels painted in Jet Black Metallic, SportDesign package painted in black (high-gloss), sports exhaust system including sports tailpipes in black, model designation painted, tinted LED taillights including light strip
- 2 SportDesign package painted in black (high-gloss), exterior mirrors painted in black (high-gloss), tinted LED main headlight with matrix beam including PDLS Plus
- 3 Interior package decorative stitching and seat centres in leather in contrasting colour (decorative stitching in Bordeaux Red/seat centres in Crayon), Porsche Crest on headrests, seat belts in Bordeaux Red
- 4 Interior package decorative stitching and seat centres in leather in contrasting colour (decorative stitching in Bordeaux Red/seat centres in Crayon), leather interior, Porsche Rear Seat Entertainment, Sport Chrono stopwatch instrument dial and rev counter in Bordeaux Red

A configuration example from the Porsche Exclusive Manufaktur.

- 1 Model logo on centre console lid, interior package decorative stitching in contrasting colour (Crayon), Crayon seat belt
- 2 Tinted LED taillights including light strip, model designation painted, sports tailpipes in silver colour, exhaust covers painted
- 3 Door sill guards in paldao, illuminated
- 4 Paldao interior package, multi-function sports steering wheel in paldao, interior package decorative stitching in contrasting colour (Crayon)
- 5 SportDesign package painted in black (high-gloss), 21-inch Exclusive Design wheels painted in black (high-gloss), exterior mirrors painted



Expression of freedom.
Even in the design.

Panamera 4S Sport Turismo in Crayon.

Exterior colours.

Solid exterior colours.



White



Black

Metallic exterior colours.



Carrara White Metallic



Rhodium Silver Metallic



Sapphire Blue Metallic



Burgundy Red Metallic



Ristretto Brown Metallic



Mahogany Metallic¹⁾



Night Blue Metallic



Agate Grey Metallic



Volcano Grey Metallic



Jet Black Metallic

Special exterior colours.



GT Silver Metallic



Crayon



Carmine Red¹⁾



Amethyst Metallic

¹⁾ Available from 11/2017 at the earliest.

Interior colours.

Standard interior colours Dashboard/trim/seats.



Black
(Roof lining: black. Carpet: black)



Agate Grey¹⁾
(Roof lining: Agate Grey. Carpet: Agate Grey)

Standard interior colours Partial leather interior. Dashboard/trim/seats.

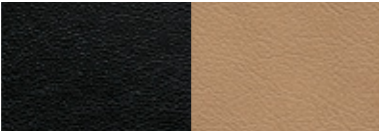

Black and Luxor Beige
(Roof lining: Luxor Beige. Carpet: black)

Standard interior colour Leather interior. Dashboard/trim/seats.



Black
(Roof lining: black. Carpet: black)



Agate Grey¹⁾
(Roof lining: Agate Grey. Carpet: Agate Grey)



Saddle Brown
(Roof lining: black. Carpet: Saddle Brown)



Marsala¹⁾
(Roof lining: black. Carpet: Marsala)

Two-tone interior Leather interior. Dashboard/trim/seats.

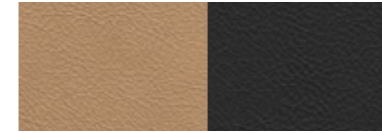

Black and Luxor Beige
(Roof lining: Luxor Beige. Carpet: black)



Black and Bordeaux Red¹⁾
(Roof lining: black. Carpet: black)

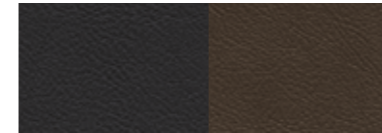

Black and Saddle Brown
(Roof lining: black. Carpet: black)



Black and Crayon
(Roof lining: Crayon. Carpet: black)



Saddle Brown and Luxor Beige
(Roof lining: Luxor Beige. Carpet: Saddle Brown)



Marsala and Cream¹⁾
(Roof lining: Cream. Carpet: Marsala)

Club leather.²⁾



Cohiba Brown
(Roof lining: Cohiba Brown. Carpet: Cohiba Brown)



Truffle Brown
(Roof lining: Truffle Brown. Carpet: Truffle Brown)

¹⁾ Provisionally available from 04/2018.

²⁾ Club leather is a deluxe, new milled nappa grade of leather that makes an especially luxurious impression with its natural light-dark contrasts and high-quality feel.



Interior packages.

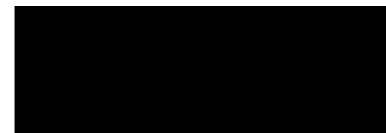

Black (high-gloss)



Dark walnut¹⁾



Paldao¹⁾

Porsche Exclusive Manufaktur



Brushed aluminium

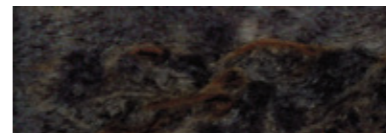

Anthracite birch¹⁾

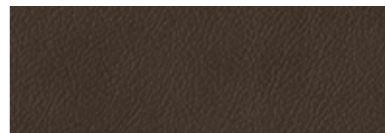

Leather

Porsche Exclusive Manufaktur

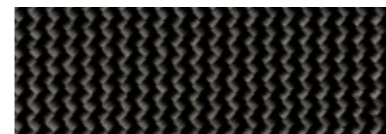

Carbon



Sweetgum¹⁾



Painted

Porsche Exclusive Manufaktur

¹⁾ Since wood is a natural product, there may be variations in colour and grain.

Possible interior colours.



Agate Grey¹⁾



Black and Luxor Beige



Black and Crayon



Cohiba Brown



Saddle Brown



Black and Bordeaux Red¹⁾



Saddle Brown and Luxor Beige



Truffle Brown



Marsala¹⁾



Black and Saddle Brown



Marsala and Cream¹⁾

¹⁾ Provisionally available from 04/2018.

Especially recommended colour combinations: exterior and interior.

	Black	Agate Grey ²⁾	Saddle Brown	Marsala ²⁾	Black and Luxor Beige	Black and Bordeaux Red ²⁾	Black and Saddle Brown	Black and Crayon	Saddle Brown and Luxor Beige
Solid colours									
Black	●	○	●	●	●	●	●	●	●
White	●	●	●	○	○	●	○	●	○
Carmine Red ¹⁾	●				○		●		
Crayon	●	●	●	●		●	●	●	●
Metallic colours									
Jet Black Metallic	●	●	●	●	●	●	●	●	●
Mahogany Metallic ¹⁾	●			○					○
Agate Grey Metallic	●	●		●	●	●	○	●	○
Rhodium Silver Metallic	●	●	●	○		●	●		
GT Silver Metallic	●	●	●	●	●	●	●		○
Sapphire Blue Metallic	●	○					○		
Night Blue Metallic	●	●	○		○		○		○
Carrara White Metallic	●	●	●	●	○	●	○	●	○

1) Provisionally available from 11/2017.

2) Provisionally available from 04/2018.

3) Club leather is a deluxe, new milled nappa grade of leather that makes an especially luxurious impression with its natural light-dark contrasts and high-quality feel.

4) Since wood is a natural product, there may be variations in colour and grain.

	Marsala and Cream ²⁾	Cohiba Brown (club leather) ³⁾	Truffle Brown (club leather) ³⁾
	●	●	●
		●	●
	●	●	●
	●	●	●
	○	●	○
		●	●
		○	●
		●	○
		○	○

● Especially recommended colour combination

○ Recommended colour combination



Paldao interior package⁴⁾

Porsche Exclusive Manufaktur



Sweetgum interior package⁴⁾

Especially recommended colour combinations: exterior and interior.

	Black	Agate Grey ²⁾	Saddle Brown	Marsala ²⁾	Black and Luxor Beige	Black and Bordeaux Red ²⁾	Black and Saddle Brown	Black and Crayon	Saddle Brown and Luxor Beige
Metallic colours									
Amethyst Metallic	●			○				●	
Volcano Grey Metallic	●	○	●	●		○	○	●	○
Burgundy Red Metallic	●					○		○	
Ristretto Brown Metallic	○		●				●		○
Interior packages									
Black (high-gloss)	●	●	●	●	●	●	●	●	●
Brushed aluminium	●	●	●		●	●	●	○	
Carbon	●	○		●	●	●	●	●	
Dark walnut ¹⁾	●		●	○	●		●		●
Anthracite birch ¹⁾	●				○			○	
Sweetgum ¹⁾	○		●	●			●		○
Paldao ¹⁾	●		○		○		○	○	

1) Since wood is a natural product, there may be variations in colour and grain.

2) Provisionally available from 04/2018.

3) Club leather is a deluxe, new milled nappa grade of leather that makes an especially luxurious impression with its natural light-dark contrasts and high-quality feel.

Marsala and Cream ²⁾	Cohiba Brown (club leather) ³⁾	Truffle Brown (club leather) ³⁾
○		
○	●	○
	●	●
●	●	●
		○
●	○	○
●	●	●

● Especially recommended colour combination

○ Recommended colour combination



Anthracite birch interior package¹⁾



Dark walnut interior package¹⁾

Thank Porsche Exclusive Manufaktur for creative freedom: interior trim packages with decorative stitching and seat centres in leather in contrasting colour.¹⁾

Personalisation.

Do you want even more creative freedom when it comes to styling the interior of your car? The interior trim packages with decorative stitching and seat centres in leather in a contrasting colour from Porsche Exclusive Manufaktur make it possible to style your Panamera Sport Turismo entirely to your own personal preference and add some interior accents of your own. These packages are available in all standard colours. Whether they are specified individually or in combination – the result will always be a visually harmonious whole, making your Panamera Sport Turismo one thing above all else: a one of a kind.

Just like you. Be inspired by the colour combinations showcased here. Or visit www.porsche.com and try out our Porsche Car Configurator.



— Interior trim package with decorative stitching in contrasting colour

— Seat centres in leather in contrasting colour

¹⁾ Provisionally available from 06/2018.



Leather in Crayon,
decorative stitching in Bordeaux Red

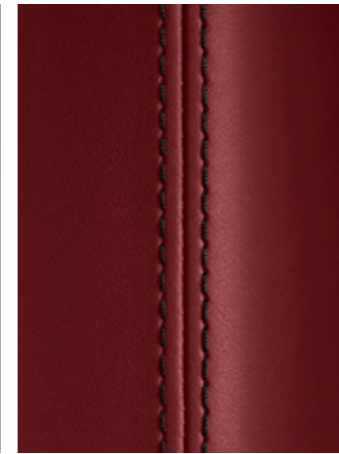

Leather in Bordeaux Red,
decorative stitching in black



Leather in Luxor Beige,
decorative stitching in Saddle Brown

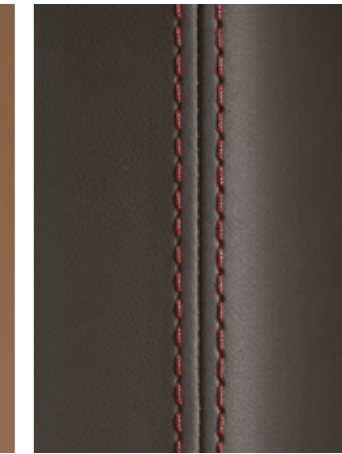

Leather in Agate Grey,
decorative stitching in Bordeaux Red



Leather in Saddle Brown,
decorative stitching in Crayon



Leather in black,
seat centre in Saddle Brown leather,
decorative stitching in Luxor Beige



Leather in Agate Grey,
seat centre in Bordeaux Red leather,
decorative stitching in Crayon



Leather in black,
seat centre in Crayon leather,
decorative stitching in Bordeaux Red



Leather in Saddle Brown,
seat centre in black leather,
decorative stitching in Luxor Beige



Leather in black,
seat centre in Marsala leather,
decorative stitching in Cream

In essence, even the details of your Porsche are a highlight.

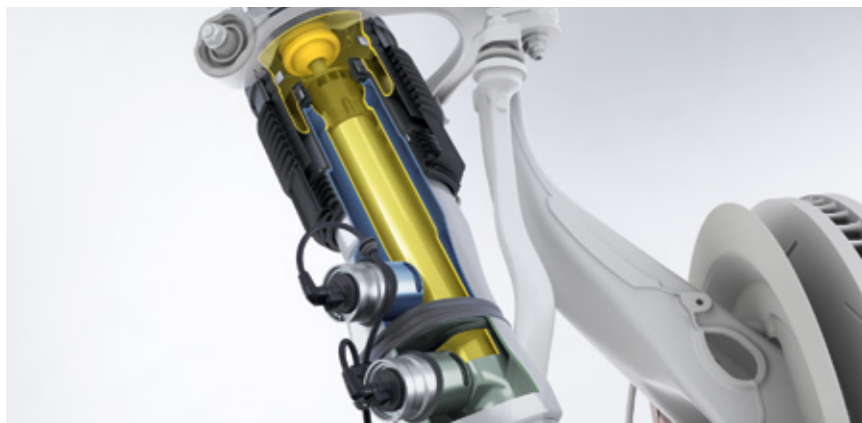

Adaptive air suspension with three-chamber technology



Porsche Ceramic Composite Brake (PCCB)



Ambient lighting

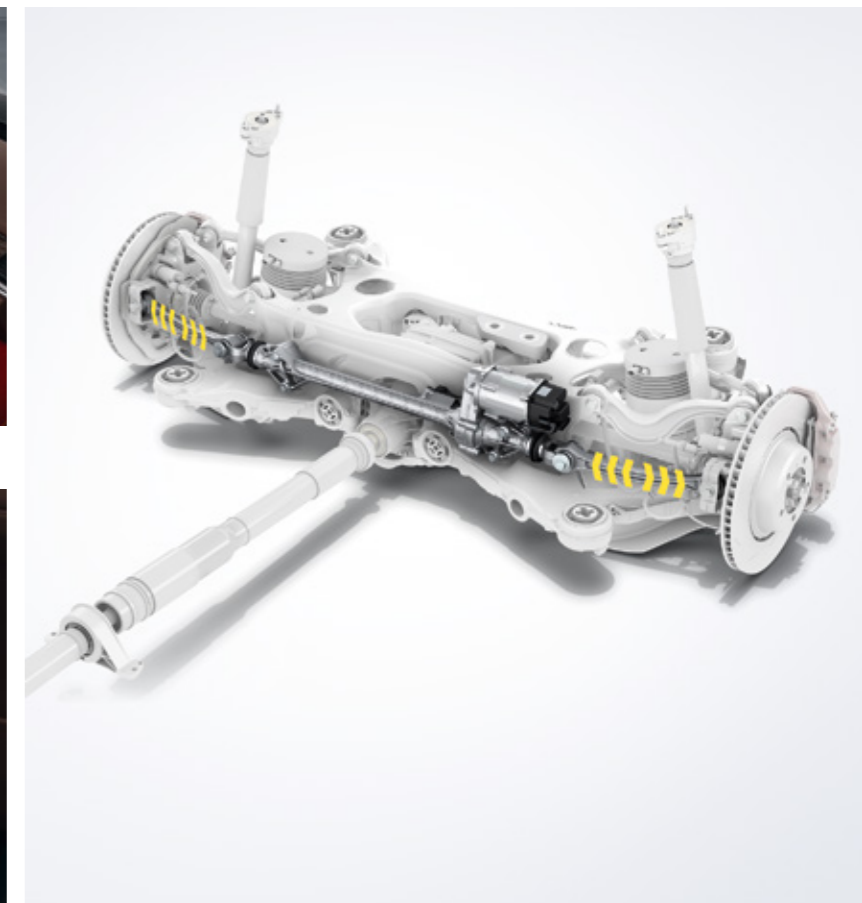

Rear-axle steering



Panoramic sunroof



Adaptive Sports seats in front (18-way, electric) with memory package and individual power seats in the rear



Four-zone automatic climate control

How do we make the extraordinary even more extraordinary?
With Porsche Exclusive Manufaktur.



SportDesign package, SportDesign package painted in black (high-gloss) Porsche Exclusive Manufaktur



21-inch Exclusive Design wheel painted in satin platinum Porsche Exclusive Manufaktur



Interior package with decorative stitching and seat centres in leather in contrasting colour Porsche Exclusive Manufaktur



Porsche Rear Seat Entertainment Porsche Exclusive Manufaktur



Sports exhaust system including sports tailpipes black (high-gloss) Porsche Exclusive Manufaktur



21-inch Panamera SportDesign wheel painted in Jet Black Metallic Porsche Exclusive Manufaktur



Vehicle key painted with key pouch in leather Porsche Exclusive Manufaktur



Model designation painted Porsche Exclusive Manufaktur



Sport Chrono Package



Sports exhaust system including sports tailpipes in brushed stainless steel *Porsche Exclusive Manufaktur*



Sports exhaust system including sports tailpipes in black (high-gloss) *Porsche Exclusive Manufaktur*

Option

Engine.

Option	Panamera 4 Sport Turismo	Panamera 4 E-Hybrid Sport Turismo	Panamera 4S Sport Turismo	Panamera Turbo Sport Turismo	Panamera Turbo S E-Hybrid Sport Turismo	I no.
Sport Chrono Package	<input type="radio"/>	<input checked="" type="radio"/>	<input type="radio"/>	<input type="radio"/>	<input checked="" type="radio"/>	QR5
Sports exhaust system including sports tailpipes in brushed stainless steel <i>Porsche Exclusive Manufaktur</i>	<input type="radio"/>	<input type="radio"/>	<input type="radio"/>	<input type="radio"/>	<input type="radio"/>	OP8
Sports exhaust system including sports tailpipes black (high-gloss) <i>Porsche Exclusive Manufaktur</i>	<input type="radio"/>	<input type="radio"/>	<input type="radio"/>	<input type="radio"/>	<input type="radio"/>	OP9
Sports tailpipes in silver colour <i>Porsche Exclusive Manufaktur</i>	<input type="radio"/>	<input type="radio"/>	<input type="radio"/>	<input type="radio"/>	<input type="radio"/>	OP3
Sports tailpipes in black <i>Porsche Exclusive Manufaktur</i>	<input type="radio"/>	<input type="radio"/>	<input type="radio"/>	<input type="radio"/>	<input type="radio"/>	OP6
90-litre fuel tank	<input type="radio"/>	<input type="radio"/>	<input type="radio"/>	<input checked="" type="radio"/>	<input type="radio"/>	OM4

Chassis.

Power steering Plus	<input type="radio"/>	<input type="radio"/>	<input type="radio"/>	<input type="radio"/>	<input checked="" type="radio"/>	1N3
Adaptive air suspension including Porsche Active Suspension Management (PASM) ²⁾	<input type="radio"/>	<input checked="" type="radio"/>	<input checked="" type="radio"/>	<input checked="" type="radio"/>	<input checked="" type="radio"/>	1BK
Porsche Dynamic Chassis Control Sport (PDCC Sport) including Porsche Torque Vectoring Plus (PTV Plus)	<input type="radio"/>	<input type="radio"/>	<input type="radio"/>	<input type="radio"/>	<input checked="" type="radio"/>	1P7
Rear-axle steering including Power steering Plus	<input type="radio"/>	<input type="radio"/>	<input type="radio"/>	<input type="radio"/>	<input type="radio"/>	ON5
Porsche Ceramic Composite Brake (PCCB)	<input type="radio"/>	<input type="radio"/>	<input type="radio"/>	<input type="radio"/>	<input checked="" type="radio"/>	1LV, 1ZQ

1) Provisionally available from 01/2018.

2) For a provisional period up to 01/2018, all Porsche Panamera Sport Turismo models cannot be ordered without optional adaptive air suspension including Porsche Active Suspension Management (PASM) (1BK). A higher vehicle price therefore applies.

3) Paint finish in exterior colour.

Option

Wheels.

Option	Panamera 4 Sport Turismo	Panamera 4 E-Hybrid Sport Turismo	Panamera 4S Sport Turismo	Panamera Turbo Sport Turismo	Panamera Turbo S E-Hybrid Sport Turismo	I no.
19-inch Panamera wheels	<input checked="" type="radio"/>	<input checked="" type="radio"/>	<input type="radio"/>	<input type="radio"/>	<input type="radio"/>	V57
19-inch Panamera S wheels	<input type="radio"/>	<input type="radio"/>	<input checked="" type="radio"/>	<input type="radio"/>	<input type="radio"/>	V58
20-inch Panamera Turbo wheels	<input type="radio"/>	<input type="radio"/>	<input type="radio"/>	<input checked="" type="radio"/>	<input type="radio"/>	44G
20-inch Panamera Design wheels	<input type="radio"/>	<input type="radio"/>	<input type="radio"/>	<input type="radio"/>	<input type="radio"/>	44H
21-inch 911 Turbo Design wheels	<input type="radio"/>	<input type="radio"/>	<input type="radio"/>	<input type="radio"/>	<input checked="" type="radio"/>	44E
21-inch Exclusive Design wheels <i>Porsche Exclusive Manufaktur</i>	<input type="radio"/>	<input type="radio"/>	<input type="radio"/>	<input type="radio"/>	<input type="radio"/>	44F
21-inch Exclusive Design wheels painted in black (high-gloss) <i>Porsche Exclusive Manufaktur</i>	<input type="radio"/>	<input type="radio"/>	<input type="radio"/>	<input type="radio"/>	<input type="radio"/>	44A
21-inch Exclusive Design wheels painted in satin platinum <i>Porsche Exclusive Manufaktur</i>	<input type="radio"/>	<input type="radio"/>	<input type="radio"/>	<input type="radio"/>	<input type="radio"/>	44C
21-inch Exclusive Design wheels painted ³⁾ <i>Porsche Exclusive Manufaktur</i>	<input type="radio"/>	<input type="radio"/>	<input type="radio"/>	<input type="radio"/>	<input type="radio"/>	43W
21-inch Exclusive Design wheels painted in Jet Black Metallic <i>Porsche Exclusive Manufaktur</i>	<input type="radio"/>	<input type="radio"/>	<input type="radio"/>	<input type="radio"/>	<input type="radio"/>	44B

– not available I number/extra-cost option Standard available at no extra cost

For more information on the options featured in this catalogue, please refer to the separate price list.



21-inch Exclusive Design wheels *Porsche Exclusive Manufaktur*



21-inch Exclusive Design wheels painted in black (high-gloss) *Porsche Exclusive Manufaktur*



21-inch Exclusive Design wheels painted *Porsche Exclusive Manufaktur*



21-inch Panamera Sport Design wheels painted in black (high-gloss) *Porsche Exclusive Manufaktur*



21-inch Panamera SportDesign wheels painted in satin platinum *Porsche Exclusive Manufaktur*



21-inch Panamera SportDesign wheels painted *Porsche Exclusive Manufaktur*

Option

Wheels.

Option	Panamera 4 Sport Turismo	Panamera 4 E-Hybrid Sport Turismo	Panamera 4S Sport Turismo	Panamera Turbo Sport Turismo	Panamera Turbo S E-Hybrid Sport Turismo	I no.
21-inch Panamera SportDesign wheels	<input type="checkbox"/>	<input type="checkbox"/>	<input type="checkbox"/>	<input type="checkbox"/>	<input type="checkbox"/>	44D
21-inch Exclusive Design wheels painted in black (high-gloss) <i>Porsche Exclusive Manufaktur</i>	<input type="checkbox"/>	<input type="checkbox"/>	<input type="checkbox"/>	<input type="checkbox"/>	<input type="checkbox"/>	43S
21-inch Panamera SportDesign wheels painted in satin platinum <i>Porsche Exclusive Manufaktur</i>	<input type="checkbox"/>	<input type="checkbox"/>	<input type="checkbox"/>	<input type="checkbox"/>	<input type="checkbox"/>	43T
21-inch Panamera SportDesign wheels painted ¹⁾ <i>Porsche Exclusive Manufaktur</i>	<input type="checkbox"/>	<input type="checkbox"/>	<input type="checkbox"/>	<input type="checkbox"/>	<input type="checkbox"/>	43V
21-inch Panamera SportDesign wheels painted in Jet Black Metallic <i>Porsche Exclusive Manufaktur</i>	<input type="checkbox"/>	<input type="checkbox"/>	<input type="checkbox"/>	<input type="checkbox"/>	<input type="checkbox"/>	43U
Wheel centres with full-colour Porsche Crest	<input type="checkbox"/>	<input type="checkbox"/>	<input type="checkbox"/>	<input type="checkbox"/>	<input type="checkbox"/>	1NP

1) Paint finish in exterior colour.
2) Paint finish in exterior colour. Front apron air intake grille slats, front apron C-blades and rear apron diffuser in satin black.
3) Paint finish in exterior colour. Front apron air intake grille slats, front apron C-blades and rear apron diffuser in black (high-gloss).

Option

Exterior.

Option	Panamera 4 Sport Turismo	Panamera 4 E-Hybrid Sport Turismo	Panamera 4S Sport Turismo	Panamera Turbo Sport Turismo	Panamera Turbo S E-Hybrid Sport Turismo	I no.
Metallic paint	<input type="checkbox"/>	<input type="checkbox"/>	<input type="checkbox"/>	<input checked="" type="checkbox"/>	<input checked="" type="checkbox"/>	Code
Special colours	<input type="checkbox"/>	<input type="checkbox"/>	<input type="checkbox"/>	<input type="checkbox"/>	<input type="checkbox"/>	Code
Custom paint	<input type="checkbox"/>	<input type="checkbox"/>	<input type="checkbox"/>	<input type="checkbox"/>	<input type="checkbox"/>	Code
Side window trims in silver colour	<input type="checkbox"/>	<input checked="" type="checkbox"/>	<input checked="" type="checkbox"/>	<input checked="" type="checkbox"/>	<input type="checkbox"/>	QJ2
Side window trims in black (high-gloss)	<input type="checkbox"/>	<input type="checkbox"/>	<input type="checkbox"/>	<input type="checkbox"/>	<input type="checkbox"/>	QJ4
SportDesign package ²⁾ <i>Porsche Exclusive Manufaktur</i>	<input type="checkbox"/>	<input type="checkbox"/>	<input type="checkbox"/>	<input type="checkbox"/>	<input type="checkbox"/>	2D1
SportDesign package painted in black (high-gloss) ³⁾ <i>Porsche Exclusive Manufaktur</i>	<input type="checkbox"/>	<input type="checkbox"/>	<input type="checkbox"/>	<input type="checkbox"/>	<input type="checkbox"/>	2D5
SportDesign sideskirts ¹⁾ <i>Porsche Exclusive Manufaktur</i>	<input type="checkbox"/>	<input type="checkbox"/>	<input type="checkbox"/>	<input type="checkbox"/>	<input type="checkbox"/>	VR4

– not available I number/extra-cost option Standard available at no extra cost
For more information on the options featured in this catalogue, please refer to the separate price list.



SportDesign package painted in black (high-gloss) *Porsche Exclusive Manufaktur*



SportDesign package painted in black (high-gloss) *Porsche Exclusive Manufaktur*



SportDesign sideskirts *Porsche Exclusive Manufaktur*



Exterior mirror painted *Porsche Exclusive Manufaktur*



Exterior mirrors painted in black (high-gloss) *Porsche Exclusive Manufaktur*



Door release levers painted in black (high-gloss) *Porsche Exclusive Manufaktur*

Option

Exterior.

Option	Panamera 4 Sport Turismo	Panamera 4 E-Hybrid Sport Turismo	Panamera 4S Sport Turismo	Panamera Turbo Sport Turismo	Panamera Turbo S E-Hybrid Sport Turismo	I no.
Exterior mirrors painted ¹⁾ <i>Porsche Exclusive Manufaktur</i>	○	○	○	○	○	6FU
Exterior mirrors painted in black (high-gloss) <i>Porsche Exclusive Manufaktur</i>	○	○	○	○	○	6FH
Air outlet trims painted ¹⁾ <i>Porsche Exclusive Manufaktur</i>	○	○	○	●	●	VK5
Air outlet trims painted in black (high-gloss) <i>Porsche Exclusive Manufaktur</i>	●	●	●	○	○	VK4
Door handles painted in black (high-gloss) <i>Porsche Exclusive Manufaktur</i>	○	○	○	○	○	6JA
Model designation painted ²⁾ <i>Porsche Exclusive Manufaktur</i>	○	○	○	○	○	AAV
Deletion of model designation	□	□	□	□	□	ONA
Preparation for towbar system	○	–	○	○	–	1D7
Electrically extending towbar system	○	–	○	○	–	1D3

1) Paint finish in exterior colour.
 2) Paint finish in exterior colour or in black (high-gloss).
 3) Provisionally available from 01/2018.
 4) For a provisional period up to 08/2018, all Porsche Panamera Sport Turismo models cannot be ordered without the optional panoramic roof system (3FU).
 A higher vehicle price therefore applies.

Option

Lights and vision.

Option	Panamera 4 Sport Turismo	Panamera 4 E-Hybrid Sport Turismo	Panamera 4S Sport Turismo	Panamera Turbo Sport Turismo	Panamera Turbo S E-Hybrid Sport Turismo	I no.
LED main headlights including PDLs	○	○	○	●	●	8IS
LED main headlights with matrix beam including PDLs Plus	○	○	○	○	○	8IU
Tinted LED main headlights with matrix beam including PDLs Plus ³⁾ <i>Porsche Exclusive Manufaktur</i>	○	○	○	○	○	8JU
Tinted LED taillights including light strip <i>Porsche Exclusive Manufaktur</i>	○	○	○	○	○	8SB
Ambient lighting	○	○	○	○	○	QQ2
Automatically dimming exterior mirrors	○	○	●	●	●	6XW/6XT

Air conditioning and glazing.

Four-zone automatic climate control	○	○	○	○	○	9AH
Active carbon fine dust filter	●	●	●	●	●	Standard
Panoramic sunroof ⁴⁾	○	○	○	○	○	3FU
Privacy glass	○	○	○	○	○	4KF
Thermally and noise insulated glass	○	○	○	○	○	VW5
Thermally and noise insulated glass including privacy glass	○	○	○	○	○	VW6

– not available ○ I number/extra-cost option ● Standard □ available at no extra cost
 For more information on the options featured in this catalogue, please refer to the separate price list.



LED main headlights with matrix beam including PDLs Plus *Porsche Exclusive Manufaktur*



Tinted LED taillights including light strip *Porsche Exclusive Manufaktur*



Privacy glass



Adaptive Sports seats in front (18-way, electric) with memory package



14-way power seats (front) with memory package

Option	Panamera 4 Sport Turismo	Panamera 4 E-Hybrid Sport Turismo	Panamera 4S Sport Turismo	Panamera Turbo Sport Turismo	Panamera Turbo S E-Hybrid Sport Turismo	I no.
Air conditioning and glazing.						
Electric roll-up sunblind for rear side windows	○	○	○	○	○	3Y7
Auxiliary heating with remote control	○	–	○	○	–	9M9
Parking pre-climatisation	–	●	–	–	●	Standard
Ioniser	○	○	○	○	○	2V4
Seats.						
Driver memory package	○	○	○	–	–	3L4
14-way power seats (front) with memory package	○	○	○	●	●	Q2J
Adaptive Sports seats in front (18-way, electric) with memory package	○	○	○	○	○	Q1J
Eight-way individual power seats (rear) with memory package ¹⁾	○	○	○	○	○	3KK
Eight-way individual power seats (rear) with memory package (in conjunction with adaptive Sports seats)	○	○	○	○	○	3KL
Seat heating (front seats)	○	○	●	–	–	4A3
Seat heating (front and rear seats)	○	○	○	●	●	4A4
Seat ventilation (front seats)	○	○	○	○	○	4D3
Seat ventilation (front and rear seats)	○	○	○	○	○	4D1

1) In conjunction with seat ventilation (front and rear) with comfort headrests.

Option	Panamera 4 Sport Turismo	Panamera 4 E-Hybrid Sport Turismo	Panamera 4S Sport Turismo	Panamera Turbo Sport Turismo	Panamera Turbo S E-Hybrid Sport Turismo	I no.
Seats.						
Massage function (front)	○	○	○	○	○	4D7
Massage function (front) with seat ventilation (front)	○	○	○	○	○	4D5
Massage function (front) with seat ventilation (front and rear)	○	○	○	○	○	4D9
Massage function (front and rear) with seat ventilation (front and rear)	○	○	○	○	○	4D2
Safety.						
Porsche Vehicle Tracking System Plus (PVTS Plus)	○	○	○	○	○	7I2
ISOFIX child seat mounting points on front passenger seat	○	○	○	○	○	3B9
Side airbags in rear compartment	○	○	○	○	○	4X4
Fire extinguisher	○	○	○	○	○	6A7
Comfort and assistance systems.						
ParkAssist including reversing camera	○	○	○	○	○	7X8
ParkAssist including Surround View	○	○	○	○	○	8A4

– not available ○ I number/extra-cost option ● Standard □ available at no extra cost
For more information on the options featured in this catalogue, please refer to the separate price list.



Eight-way individual power seats (rear) with memory package



Massage function (front and rear)

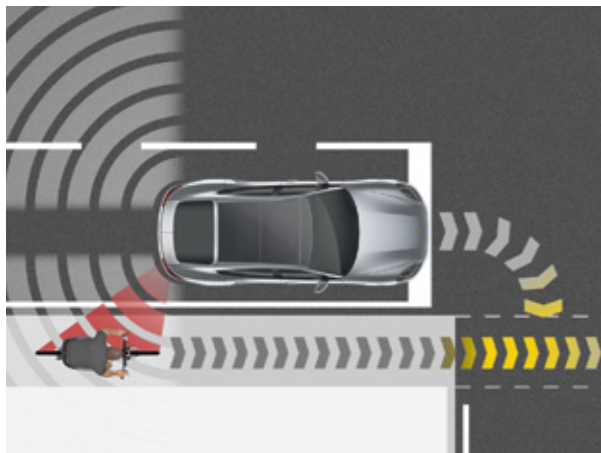

Lane Change Assist with Turn Assist



Lane Keeping Assist including traffic sign recognition

Option

Comfort and assistance systems.

Option	Panamera 4 Sport Turismo	Panamera 4 E-Hybrid Sport Turismo	Panamera 4S Sport Turismo	Panamera Turbo Sport Turismo	Panamera Turbo S E-Hybrid Sport Turismo	I no.
Lane Change Assist	<input type="checkbox"/>	<input type="checkbox"/>	<input type="checkbox"/>	<input type="checkbox"/>	<input type="checkbox"/>	7Y1
Lane Keeping Assist including traffic sign recognition	<input type="checkbox"/>	<input type="checkbox"/>	<input type="checkbox"/>	<input type="checkbox"/>	<input type="checkbox"/>	P8A
Adaptive cruise control	<input type="checkbox"/>	<input type="checkbox"/>	<input type="checkbox"/>	<input type="checkbox"/>	<input type="checkbox"/>	8T3
Porsche InnoDrive including adaptive cruise control	<input type="checkbox"/>	<input type="checkbox"/>	<input type="checkbox"/>	<input type="checkbox"/>	<input type="checkbox"/>	P8D
Night Vision Assist	<input type="checkbox"/>	<input type="checkbox"/>	<input type="checkbox"/>	<input type="checkbox"/>	<input type="checkbox"/>	9R1
Comfort Access ¹⁾	<input type="checkbox"/>	<input type="checkbox"/>	<input type="checkbox"/>	<input checked="" type="checkbox"/>	<input checked="" type="checkbox"/>	4F2
Soft-close doors	<input type="checkbox"/>	<input type="checkbox"/>	<input type="checkbox"/>	<input type="checkbox"/>	<input type="checkbox"/>	GZ2
HomeLink® (programmable garage door opener)	<input type="checkbox"/>	<input type="checkbox"/>	<input type="checkbox"/>	<input type="checkbox"/>	<input type="checkbox"/>	VC1

Interior.

Steering wheel heating	<input type="checkbox"/>	<input type="checkbox"/>	<input type="checkbox"/>	<input type="checkbox"/>	<input type="checkbox"/>	2ZH
Cupholder cover in front	<input type="checkbox"/>	<input type="checkbox"/>	<input type="checkbox"/>	<input type="checkbox"/>	<input type="checkbox"/>	4M1
Smoking package	<input type="checkbox"/>	<input type="checkbox"/>	<input type="checkbox"/>	<input type="checkbox"/>	<input type="checkbox"/>	9JB
Interior package in black (high-gloss)	<input checked="" type="checkbox"/>	<input checked="" type="checkbox"/>	<input checked="" type="checkbox"/>	<input type="checkbox"/>	<input type="checkbox"/>	5TL

1) Comfort Access uses state of the art technology. However, it cannot be completely ruled out that the key's wireless encryption code is intercepted and used to open or steal the vehicle.
 2) Free choice of colour (at no extra cost) from all available standard and special colours.
 3) Provisionally available from 01/2018.
 4) Finish in exterior colour, also available in different exterior colours. Free choice of colour (at no extra cost) from all standard and special colours.
 5) Paint finish in exterior colour, leather in interior colour.

Option

Interior.

Option	Panamera 4 Sport Turismo	Panamera 4 E-Hybrid Sport Turismo	Panamera 4S Sport Turismo	Panamera Turbo Sport Turismo	Panamera Turbo S E-Hybrid Sport Turismo	I no.
Interior package painted <i>Porsche Exclusive Manufaktur</i>	<input type="checkbox"/>	<input type="checkbox"/>	<input type="checkbox"/>	<input type="checkbox"/>	<input type="checkbox"/>	
– in exterior colour	<input type="checkbox"/>	<input type="checkbox"/>	<input type="checkbox"/>	<input type="checkbox"/>	<input type="checkbox"/>	7TL
– in contrasting exterior colour ²⁾	<input type="checkbox"/>	<input type="checkbox"/>	<input type="checkbox"/>	<input type="checkbox"/>	<input type="checkbox"/>	APC
Air vents painted ^{3), 4)} <i>Porsche Exclusive Manufaktur</i>	<input type="checkbox"/>	<input type="checkbox"/>	<input type="checkbox"/>	<input type="checkbox"/>	<input type="checkbox"/>	AVF
Seat belts coloured <i>Porsche Exclusive Manufaktur</i>	<input type="checkbox"/>	<input type="checkbox"/>	<input type="checkbox"/>	<input type="checkbox"/>	<input type="checkbox"/>	
– Crayon	<input type="checkbox"/>	<input type="checkbox"/>	<input type="checkbox"/>	<input type="checkbox"/>	<input type="checkbox"/>	FI8
– Bordeaux Red	<input type="checkbox"/>	<input type="checkbox"/>	<input type="checkbox"/>	<input type="checkbox"/>	<input type="checkbox"/>	FI6
Floor mats	<input type="checkbox"/>	<input type="checkbox"/>	<input checked="" type="checkbox"/>	<input checked="" type="checkbox"/>	<input type="checkbox"/>	OTD
Vehicle key painted with key pouch in leather ⁵⁾ <i>Porsche Exclusive Manufaktur</i>	<input type="checkbox"/>	<input type="checkbox"/>	<input type="checkbox"/>	<input type="checkbox"/>	<input type="checkbox"/>	BFL
Sport Chrono stopwatch instrument dial coloured <i>Porsche Exclusive Manufaktur</i>	<input type="checkbox"/>	<input type="checkbox"/>	<input type="checkbox"/>	<input type="checkbox"/>	<input type="checkbox"/>	
– White	<input type="checkbox"/>	<input type="checkbox"/>	<input type="checkbox"/>	<input type="checkbox"/>	<input type="checkbox"/>	UP3
– Luxor Beige	<input type="checkbox"/>	<input type="checkbox"/>	<input type="checkbox"/>	<input type="checkbox"/>	<input type="checkbox"/>	UP4
– Bordeaux Red	<input type="checkbox"/>	<input type="checkbox"/>	<input type="checkbox"/>	<input type="checkbox"/>	<input type="checkbox"/>	UP6

– not available I number/extra-cost option Standard available at no extra cost
 For more information on the options featured in this catalogue, please refer to the separate price list.



Interior package painted *Porsche Exclusive Manufaktur*



Air vents painted *Porsche Exclusive Manufaktur*



Seat belts in Crayon *Porsche Exclusive Manufaktur*



Rev counter instrument dial in Bordeaux Red *Porsche Exclusive Manufaktur*



Leather interior package *Porsche Exclusive Manufaktur*



Interior additional package dashboard leather *Porsche Exclusive Manufaktur*

Option

Interior.

Rev counter instrument dial coloured

Porsche Exclusive Manufaktur

- White
- Luxor Beige
- Bordeaux Red

Interior: leather.

Interior in standard colour

Partial leather interior in two-tone combination

Leather interior in standard colour, smooth-finish leather

Two-tone leather interior, smooth-finish leather

Club leather interior

Omission of embossed "turbo" or "turbo S" logo on headrests

Leather interior package

Porsche Exclusive Manufaktur

- in interior colour
- in contrasting interior colour¹⁾

Interior trim package with decorative stitching in contrasting colour²⁾

Porsche Exclusive Manufaktur

	Panamera 4 Sport Turismo	Panamera 4 E-Hybrid Sport Turismo	Panamera 4S Sport Turismo	Panamera Turbo Sport Turismo	Panamera Turbo S E-Hybrid Sport Turismo	I no.
Rev counter instrument dial coloured	<input type="checkbox"/>	<input type="checkbox"/>	<input type="checkbox"/>	<input type="checkbox"/>	<input type="checkbox"/>	7V3
– White	<input type="checkbox"/>	<input type="checkbox"/>	<input type="checkbox"/>	<input type="checkbox"/>	<input type="checkbox"/>	7V4
– Luxor Beige	<input type="checkbox"/>	<input type="checkbox"/>	<input type="checkbox"/>	<input type="checkbox"/>	<input type="checkbox"/>	7V2
– Bordeaux Red	<input type="checkbox"/>	<input type="checkbox"/>	<input type="checkbox"/>	<input type="checkbox"/>	<input type="checkbox"/>	
Interior in standard colour	<input checked="" type="checkbox"/>	<input checked="" type="checkbox"/>	<input checked="" type="checkbox"/>	<input type="checkbox"/>	<input type="checkbox"/>	Standard
Partial leather interior in two-tone combination	<input type="checkbox"/>	<input type="checkbox"/>	<input type="checkbox"/>	<input type="checkbox"/>	<input type="checkbox"/>	Code
Leather interior in standard colour, smooth-finish leather	<input type="checkbox"/>	<input type="checkbox"/>	<input type="checkbox"/>	<input checked="" type="checkbox"/>	<input checked="" type="checkbox"/>	Code
Two-tone leather interior, smooth-finish leather	<input type="checkbox"/>	<input type="checkbox"/>	<input type="checkbox"/>	<input type="checkbox"/>	<input type="checkbox"/>	Code
Club leather interior	<input type="checkbox"/>	<input type="checkbox"/>	<input type="checkbox"/>	<input type="checkbox"/>	<input type="checkbox"/>	Code
Omission of embossed "turbo" or "turbo S" logo on headrests	<input type="checkbox"/>	<input type="checkbox"/>	<input type="checkbox"/>	<input type="checkbox"/>	<input type="checkbox"/>	3J4
Leather interior package	<input type="checkbox"/>	<input type="checkbox"/>	<input type="checkbox"/>	<input type="checkbox"/>	<input type="checkbox"/>	
<i>Porsche Exclusive Manufaktur</i>	<input type="checkbox"/>	<input type="checkbox"/>	<input type="checkbox"/>	<input type="checkbox"/>	<input type="checkbox"/>	
– in interior colour	<input type="checkbox"/>	<input type="checkbox"/>	<input type="checkbox"/>	<input type="checkbox"/>	<input type="checkbox"/>	7TM
– in contrasting interior colour ¹⁾	<input type="checkbox"/>	<input type="checkbox"/>	<input type="checkbox"/>	<input type="checkbox"/>	<input type="checkbox"/>	APL
Interior trim package with decorative stitching in contrasting colour ²⁾	<input type="checkbox"/>	<input type="checkbox"/>	<input type="checkbox"/>	<input type="checkbox"/>	<input type="checkbox"/>	AZD
<i>Porsche Exclusive Manufaktur</i>	<input type="checkbox"/>	<input type="checkbox"/>	<input type="checkbox"/>	<input type="checkbox"/>	<input type="checkbox"/>	

1) Free choice of colour (at no extra cost) from all available standard colours.

2) Provisionally available from 06/2018.

3) Leather trim in interior colour. Available in contrasting colours. Free choice of colour (at no extra cost) from all standard and club leather colours.

4) Provisionally available from 01/2018.

5) Unless specified when ordering, leather trim in two-tone combination is applied to the darker louvred slats in the dashboard area, and the lighter leather colour in the rear area.

Option

Interior: leather.

Seat centres in leather in contrasting colour²⁾

Porsche Exclusive Manufaktur

Interior trim package with decorative stitching and seat centres in leather in contrasting colour²⁾

Porsche Exclusive Manufaktur

Porsche Crest embossed on headrests

Porsche Exclusive Manufaktur

Porsche Crest embossed on centre console armrests

Porsche Exclusive Manufaktur

Model logo embossed on centre console armrests

Porsche Exclusive Manufaktur

Steering column casing and instrument surround in leather

Porsche Exclusive Manufaktur

Interior additional package dashboard leather³⁾

Porsche Exclusive Manufaktur

Air vents in leather^{3), 4), 5)}

Porsche Exclusive Manufaktur

Leather seat consoles

Porsche Exclusive Manufaktur

– Seat consoles front

– Seat consoles front and rear

	Panamera 4 Sport Turismo	Panamera 4 E-Hybrid Sport Turismo	Panamera 4S Sport Turismo	Panamera Turbo Sport Turismo	Panamera Turbo S E-Hybrid Sport Turismo	I no.
Seat centres in leather in contrasting colour ²⁾	<input type="checkbox"/>	<input type="checkbox"/>	<input type="checkbox"/>	<input type="checkbox"/>	<input type="checkbox"/>	AZB
Interior trim package with decorative stitching and seat centres in leather in contrasting colour ²⁾	<input type="checkbox"/>	<input type="checkbox"/>	<input type="checkbox"/>	<input type="checkbox"/>	<input type="checkbox"/>	AZE
Porsche Crest embossed on headrests	<input type="checkbox"/>	<input type="checkbox"/>	<input type="checkbox"/>	<input type="checkbox"/>	<input type="checkbox"/>	5ZF
Porsche Crest embossed on centre console armrests	<input type="checkbox"/>	<input type="checkbox"/>	<input type="checkbox"/>	<input type="checkbox"/>	<input type="checkbox"/>	6E2
Model logo embossed on centre console armrests	<input type="checkbox"/>	<input type="checkbox"/>	<input type="checkbox"/>	<input type="checkbox"/>	<input type="checkbox"/>	6E3
Steering column casing and instrument surround in leather	<input type="checkbox"/>	<input type="checkbox"/>	<input type="checkbox"/>	<input type="checkbox"/>	<input type="checkbox"/>	ALK
Interior additional package dashboard leather ³⁾	<input type="checkbox"/>	<input type="checkbox"/>	<input type="checkbox"/>	<input type="checkbox"/>	<input type="checkbox"/>	AZW
Air vents in leather ^{3), 4), 5)}	<input type="checkbox"/>	<input type="checkbox"/>	<input type="checkbox"/>	<input type="checkbox"/>	<input type="checkbox"/>	AVG
Leather seat consoles	<input type="checkbox"/>	<input type="checkbox"/>	<input type="checkbox"/>	<input type="checkbox"/>	<input type="checkbox"/>	
<i>Porsche Exclusive Manufaktur</i>	<input type="checkbox"/>	<input type="checkbox"/>	<input type="checkbox"/>	<input type="checkbox"/>	<input type="checkbox"/>	
– Seat consoles front	<input type="checkbox"/>	<input type="checkbox"/>	<input type="checkbox"/>	<input type="checkbox"/>	<input type="checkbox"/>	ALS
– Seat consoles front and rear	<input type="checkbox"/>	<input type="checkbox"/>	<input type="checkbox"/>	<input type="checkbox"/>	<input type="checkbox"/>	ALV



Porsche Crest on armrests centre console *Porsche Exclusive Manufaktur*



Steering column and frame instrument cluster in leather *Porsche Exclusive Manufaktur*



Air vents in leather *Porsche Exclusive Manufaktur*

– not available I number/extra-cost option Standard available at no extra cost
For more information on the options featured in this catalogue, please refer to the separate price list.



Brushed aluminium interior package



Carbon interior package



Door sill guard in carbon *Porsche Exclusive Manufaktur*

Option

Interior: Alcantara®.

Option	Panamera 4 Sport Turismo	Panamera 4 E-Hybrid Sport Turismo	Panamera 4S Sport Turismo	Panamera Turbo Sport Turismo	Panamera Turbo S E-Hybrid Sport Turismo	I no.
Roof lining in Alcantara®	<input type="checkbox"/>	<input type="checkbox"/>	<input type="checkbox"/>	<input checked="" type="checkbox"/>	<input checked="" type="checkbox"/>	6NN

Interior: aluminium.

Brushed aluminium interior package	<input type="checkbox"/>	<input type="checkbox"/>	<input type="checkbox"/>	<input type="checkbox"/>	<input type="checkbox"/>	5TE
------------------------------------	--------------------------	--------------------------	--------------------------	--------------------------	--------------------------	-----

Door sill guards in brushed aluminium, illuminated <i>Porsche Exclusive Manufaktur</i>	<input type="checkbox"/>	<input type="checkbox"/>	<input type="checkbox"/>	<input type="checkbox"/>	<input type="checkbox"/>	VT2
---	--------------------------	--------------------------	--------------------------	--------------------------	--------------------------	-----

Personalised door sill guards in brushed aluminium illuminated <i>Porsche Exclusive Manufaktur</i>	<input type="checkbox"/>	<input type="checkbox"/>	<input type="checkbox"/>	<input type="checkbox"/>	<input type="checkbox"/>	ATV
---	--------------------------	--------------------------	--------------------------	--------------------------	--------------------------	-----

Interior: carbon.

Carbon interior package	<input type="checkbox"/>	<input type="checkbox"/>	<input type="checkbox"/>	<input type="checkbox"/>	<input type="checkbox"/>	5MH
-------------------------	--------------------------	--------------------------	--------------------------	--------------------------	--------------------------	-----

Heated multifunction sports steering wheel in carbon with gearshift paddles	<input type="checkbox"/>	<input type="checkbox"/>	<input type="checkbox"/>	<input type="checkbox"/>	<input type="checkbox"/>	2FX
---	--------------------------	--------------------------	--------------------------	--------------------------	--------------------------	-----

Door sill guards in carbon <i>Porsche Exclusive Manufaktur</i>	<input type="checkbox"/>	<input type="checkbox"/>	<input type="checkbox"/>	<input type="checkbox"/>	<input type="checkbox"/>	7M3
---	--------------------------	--------------------------	--------------------------	--------------------------	--------------------------	-----

Door sill guards in carbon, illuminated <i>Porsche Exclusive Manufaktur</i>	<input type="checkbox"/>	<input type="checkbox"/>	<input type="checkbox"/>	<input type="checkbox"/>	<input type="checkbox"/>	7M8
--	--------------------------	--------------------------	--------------------------	--------------------------	--------------------------	-----

1) Leather edging and stitching available in all standard colours.
2) Since wood is a natural product, there may be variations in colour and grain.

Option

Interior: carbon.

Personalised door sill guards illuminated <i>Porsche Exclusive Manufaktur</i>	<input type="checkbox"/>	<input type="checkbox"/>	<input type="checkbox"/>	<input type="checkbox"/>	<input type="checkbox"/>	ADY
--	--------------------------	--------------------------	--------------------------	--------------------------	--------------------------	-----

Personalised floor mats in carbon with leather edging ¹⁾ <i>Porsche Exclusive Manufaktur</i>	<input type="checkbox"/>	<input type="checkbox"/>	<input type="checkbox"/>	<input type="checkbox"/>	<input type="checkbox"/>	ACJ
--	--------------------------	--------------------------	--------------------------	--------------------------	--------------------------	-----

Interior: wood²⁾.

Interior package	<input type="checkbox"/>	<input type="checkbox"/>	<input type="checkbox"/>	<input type="checkbox"/>	<input type="checkbox"/>	
– in dark walnut	<input type="checkbox"/>	<input type="checkbox"/>	<input type="checkbox"/>	<input checked="" type="checkbox"/>	<input checked="" type="checkbox"/>	5MP
– in anthracite birch	<input type="checkbox"/>	<input type="checkbox"/>	<input type="checkbox"/>	<input type="checkbox"/>	<input type="checkbox"/>	5MB
– in sweetgum	<input type="checkbox"/>	<input type="checkbox"/>	<input type="checkbox"/>	<input type="checkbox"/>	<input type="checkbox"/>	7TD
– in paldao	<input type="checkbox"/>	<input type="checkbox"/>	<input type="checkbox"/>	<input type="checkbox"/>	<input type="checkbox"/>	7TC

Heated multifunction sports steering wheel with gearshift paddles	<input type="checkbox"/>	<input type="checkbox"/>	<input type="checkbox"/>	<input type="checkbox"/>	<input type="checkbox"/>	
– in dark walnut	<input type="checkbox"/>	<input type="checkbox"/>	<input type="checkbox"/>	<input type="checkbox"/>	<input type="checkbox"/>	1XG
– in anthracite birch	<input type="checkbox"/>	<input type="checkbox"/>	<input type="checkbox"/>	<input type="checkbox"/>	<input type="checkbox"/>	1XE
– in sweetgum	<input type="checkbox"/>	<input type="checkbox"/>	<input type="checkbox"/>	<input type="checkbox"/>	<input type="checkbox"/>	2FF
– in paldao	<input type="checkbox"/>	<input type="checkbox"/>	<input type="checkbox"/>	<input type="checkbox"/>	<input type="checkbox"/>	2FG

Door sill guards in paldao, illuminated <i>Porsche Exclusive Manufaktur</i>	<input type="checkbox"/>	<input type="checkbox"/>	<input type="checkbox"/>	<input type="checkbox"/>	<input type="checkbox"/>	ATP
--	--------------------------	--------------------------	--------------------------	--------------------------	--------------------------	-----

– not available I number/extra-cost option Standard available at no extra cost
For more information on the options featured in this catalogue, please refer to the separate price list.



Personalised floor mats in carbon with leather edging *Porsche Exclusive Manufaktur*



Door sill guards in paldao, illuminated *Porsche Exclusive Manufaktur*



Porsche Rear Seat Entertainment *Porsche Exclusive Manufaktur*



Digital radio

Option

Audio and communication.

Option	Panamera 4 Sport Turismo	Panamera 4 E-Hybrid Sport Turismo	Panamera 4S Sport Turismo	Panamera Turbo Sport Turismo	Panamera Turbo S E-Hybrid Sport Turismo	I no.
Porsche Communication Management (PCM) including online navigation	●	●	●	●	●	Standard
Connect Plus, including online navigation, Apple® CarPlay, LTE telephone module with SIM card reader, smartphone compartment, wireless Internet access, Porsche Car Connect and comprehensive Porsche Connect services ¹⁾	●	●	●	●	●	Standard
BOSE® Surround Sound System	○	○	○	●	●	9VL
Burmester® High-End 3D Surround Sound System	○	○	○	○	○	9VJ
Six-disc CD/DVD autochanger	○	○	○	○	○	6G2
Digital radio	○	○	○	○	○	QV3
Preparation for Porsche Rear Seat Entertainment <i>Porsche Exclusive Manufaktur</i>	○	○	○	○	○	9WU
Porsche Rear Seat Entertainment <i>Porsche Exclusive Manufaktur</i>	○	○	○	○	○	9WY
USB interface in rear	○	○	○	○	○	UI2

Luggage and storage compartments.

Storage package	□	□	□	□	□	QE1
Ski bag	○	○	○	○	○	3X1

¹⁾ See note on page 91.

Option

Luggage and storage compartments.

Loadspace management system including luggage compartment partition net	○	○	○	○	○	3GN
230-V socket in luggage compartment	○	○	○	○	○	9Z3

E-Performance.

On-board charger with 7.2-kW charging output	–	○	–	–	○	KB2
Porsche Charging Dock for docking the Porsche Universal Charger (AC)	–	○	–	–	○	NJ1
Vehicle cable	–	●	–	–	●	Standard
Supply cable for domestic electrical socket	–	●	–	–	●	Standard
Supply cable for industrial electrical outlet	–	●	–	–	●	Standard
Charging cable (mode 3) for charging at public charging pedestals	–	○	–	–	○	TEQ
Charging pedestal	–	○	–	–	○	TEQ

Factory collection.

Factory collection in Zuffenhausen	○	○	○	○	○	SZ8
Factory collection in Leipzig including intensive driving induction	○	○	○	○	○	S9Y

– not available ○ I number/extra-cost option ● Standard □ available at no extra cost
For more information on the options featured in this catalogue, please refer to the separate price list.



Charging cable (mode 3)



Charging pedestal

Accessories developed for 365 days full of life.

Porsche Tequipment.

With the Porsche Tequipment range of accessories developed specifically for your Panamera Sport Turismo, you can style it entirely to your own preference. From the start, the same rules that apply to our vehicles also apply to the products of Porsche Tequipment: developed, tested and proven at the Development Centre in Weissach. By the same Porsche engineers and designers who made your car. Designed with the complete vehicle in mind and precisely tailored to your Porsche.

And your original car warranty? It will remain completely intact, whichever Tequipment products you ask your Porsche Centre to fit.

To discover more about Porsche Tequipment, please consult your Porsche Centre. Alternatively, all Tequipment products can be found online at www.porsche.com/tequipment using our 'Tequipment accessories finder'.

1 Roof boxes

Lockable plastic roof boxes in black (high-gloss) or platinum look, with a capacity of approximately 320 or 520 litres.

2 Porsche Charge-o-mat Pro

Faster charging time thanks to its increased charging power.

3 Wheels with winter tyres

For enhanced individuality, agility and safety. And even greater driving pleasure.

4 Tequipment accessories finder including QR code



Porsche Car Configurator.

Taste, personality and style. You decide how to refine the Panamera to your personal preference. With the Porsche Car Configurator, you can see the result instantly on your computer. Just four steps are all it takes to create your own Porsche.

It's as simple as selecting or deselecting the options you want. The price is recalculated automatically with each click. It looks stunning, too, because all features are rendered in 3D. So you can view your configuration from any angle, save it and print it off there and then.

Visit www.porsche.com to find the Porsche Car Configurator and discover much more about the fascination of Porsche.

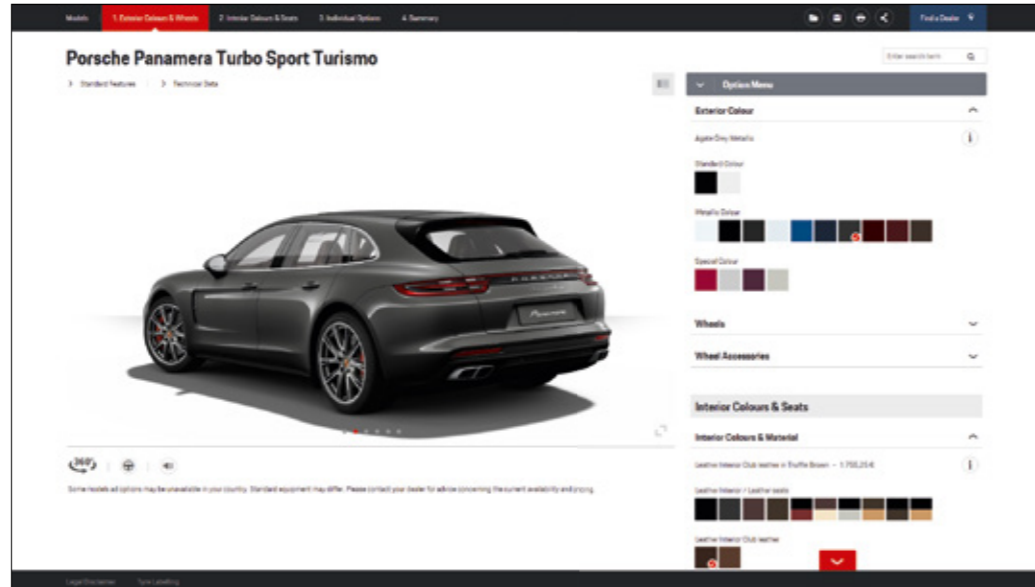

Designing your Porsche.

Consultation.

At your Porsche Centre, we're on hand to answer all your questions about your new Porsche. Of course, the same applies to the personalisation options of Porsche Exclusive Manufaktur.

In our Customer Centres in Zuffenhausen and Leipzig, we will show you what else can be done. Here, you can select your materials and paint colours and plan your vehicle in detail using the Porsche Car Configurator.

Factory collection.

Once the planning is over, the anticipation begins – looking forward to the day of delivery. The Porsche factory collection makes this an event to cherish even more. Stuttgart or Leipzig? Both venues hold their own special allure. In Stuttgart-Zuffenhausen, you can experience and learn about every aspect of the legendary Porsche brand. In addition to receiving a detailed lowdown on your car, you will also gain an insight into the entire history of Porsche with a visit to the Porsche Museum. Legendary models from a sports car history spanning more than six decades await. At our Leipzig location, you're going to take to the starting grid – in a Porsche model identical to the one you

purchased and under the expert supervision of one of our instructors. During the drive, they will demonstrate all the functions of your new Porsche. And, indeed, the potential that lies within. On-road on the racetrack. Or off-road, on our very own off-road track. Whichever location you choose, your itinerary includes a guided factory tour, a stylish lunch and, of course, the moment you've been waiting for: taking delivery of your Porsche. To arrange a date for your factory collection experience, please consult your Porsche Centre. There, you will be given all the relevant further information about current availability and the formalities, legal or otherwise, that need to be completed before you can take delivery.



Porsche World.



Porsche Centres

Your Porsche Centre can assist you with every aspect of purchasing and owning your Porsche. You will also find a wide range of products and services, including genuine Porsche parts and top-quality accessories.



Porsche Exclusive Manufaktur

Realise your vision of the perfect Porsche with our factory customisation programme. From styling enhancements to performance upgrades, all modifications are uniquely handcrafted for your Porsche.



Porsche Tequipment

Personalise your Porsche at any time after purchase with our range of aftermarket accessories. You will also find all our available products online at www.porsche.com/tequipment using the Tequipment accessories finder.



Porsche Driver's Selection

With leisurewear, model cars, timepieces, leather goods, luggage specifically tailored to Porsche luggage compartments and other intelligent accessories, there are plenty of opportunities to indulge your passion for Porsche off the road, too.



Porsche Travel Club

Embark on a thrilling adventure and feel the power of Porsche. Stay in top-class hotels and dine in five-star restaurants – in the most beautiful places on Earth. To find out more, call +49 711 911-23360. E-mail: info@porschetravelclub.de



Porsche Sport Driving School

Develop your skill and explore your Porsche with the Porsche Sport Driving School. Learn about events at some of the world's most famous racing venues, call +49 711 911-23364. E-mail: info@porscheporstdrivingsschool.de



Porsche Clubs

Since the first Porsche Club was founded in 1952, their number has grown to 660 with a total of 195,000 members worldwide. To find out more, go to www.porsche.com/clubs or call +49 711 911-23250. E-mail: communitymanagement@porsche.de

Porsche Service

Your expert partner for all current Porsche models as well as old and modern classics, whether your car needs servicing, routine care or special repairs.

Porsche Assistance

Enjoy peace of mind with our exclusive breakdown and accident recovery service. Membership is free when you buy a new Porsche.

Porsche Approved

So that our vehicles remain reliable and retain their value whether new or previously owned, all Porsche Approved cars meet the most stringent Porsche quality standards across the world. Each car is backed by the Porsche Approved warranty.

Porsche Financial Services

Discover our financial services and realise your dream of the sports car with the solutions we have to offer. Uncomplicated. Individual. Tailored.

Christophorus

Published five times a year, our magazine for Porsche owners offers news, interviews and a variety of features from throughout the world of Porsche. Visit www.porsche.com/christophorus for a selection of online articles.

Porsche Classic

Your specialist source for genuine Porsche parts as well as restoration services for all Porsche classics. Visit www.porsche.com/classic to find out more.

Porsche Museum

More than 80 vehicles at our headquarters in Stuttgart-Zuffenhausen await to take you on a journey through Porsche history. See icons such as the 356, 911 and 917 presented in an atmosphere you can't experience anywhere else.

Porsche Online

Go to www.porsche.com for all the latest news and information from Porsche.



You can obtain the latest brochures for Porsche Driving Experience, Porsche Driver's Selection and Porsche Tequipment from your Porsche Centre.

Technical data.

	Panamera 4 Sport Turismo	Panamera 4S Sport Turismo
Engine		
Type	V6 turbo	V6 twin-turbo
Cylinders	6	6
Displacement	2,995 cm ³	2,894 cm ³
Max. power (DIN) at rpm	243 kW (330 hp) at 5,400–6,400	324 kW (440 hp) at 5,650–6,600
Max. torque at rpm	450 Nm at 1,340–4,900	550 Nm at 1,750–5,500
Transmission		
Layout	All-wheel drive	All-wheel drive
Porsche Doppelkupplung (PDK)	8-speed	8-speed
Chassis		
Front axle	Fully independent aluminium double wishbone suspension	Fully independent aluminium double wishbone suspension
Rear axle	Fully independent aluminium multi-link suspension with chassis subframe, independent suspension	Fully independent aluminium multi-link suspension with chassis subframe, independent suspension
Steering	Power-assisted (electromechanical)	Power-assisted (electromechanical)
Brakes	Six-piston aluminium monobloc fixed brake calipers at front, four-piston units at rear	Six-piston aluminium monobloc fixed brake calipers at front, four-piston units at rear
Standard wheels	Front: 9.0 J x 19 ET 64 Rear: 10.5 J x 19 ET 62	Front: 9.0 J x 19 ET 64 Rear: 10.5 J x 19 ET 62
Standard tyres	Front: 265/45 ZR 19 Rear: 295/40 ZR 19	Front: 265/45 ZR 19 Rear: 295/40 ZR 19

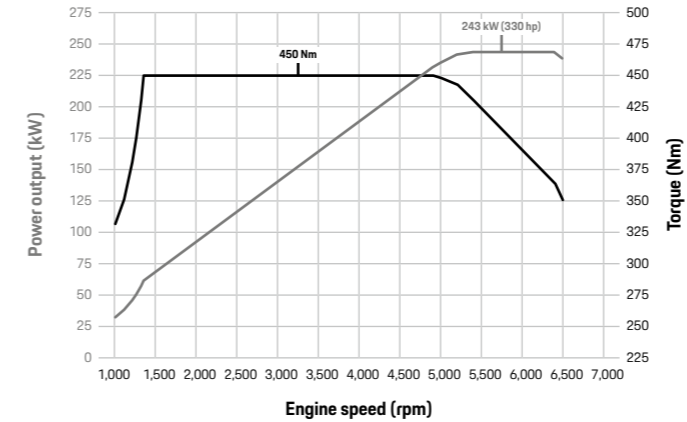

Panamera 4 Sport Turismo: 243 kW (330 hp) between 5,400–6,400 rpm, 450 Nm between 1,340–4,900 rpm

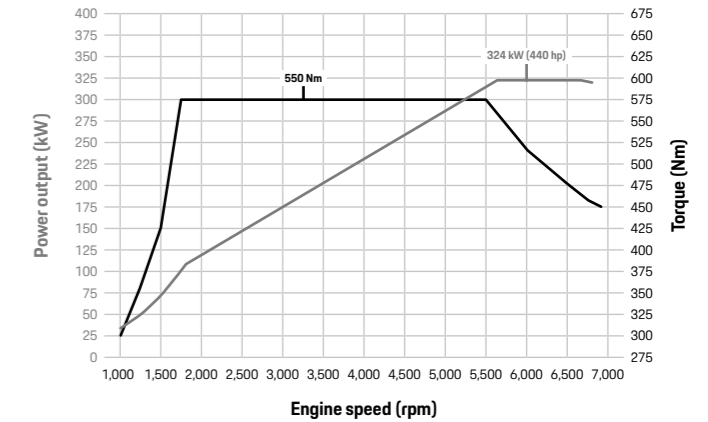

Panamera 4S Sport Turismo: 324 kW (440 hp) between 5,650–6,600 rpm, 550 Nm between 1,750–5,500 rpm

Technical data.

Panamera Turbo Sport Turismo

Engine

Type	V8 twin-turbo
Cylinders	8
Displacement	3,996 cm ³
Max. power (DIN) at rpm	404 kW (550 hp) at 5,750–6,000
Max. torque at rpm	770 Nm at 1,960–4,500

Transmission

Layout	All-wheel drive
Porsche Doppelkupplung (PDK)	8-speed

Chassis

Front axle	Fully independent aluminium double wishbone suspension
Rear axle	Fully independent aluminium multi-link suspension with chassis subframe, independent suspension
Steering	Power-assisted (electromechanical)
Brakes	Six-piston aluminium monobloc fixed brake calipers at front, four-piston units at rear
Standard wheels	Front: 9.5 J x 20 ET 71 Rear: 11.5 J x 20 ET 68
Standard tyres	Front: 275/40 ZR 20 Rear: 315/35 ZR 20

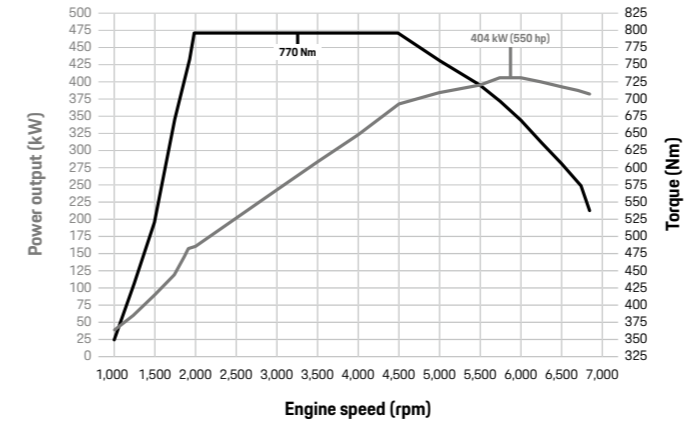

Panamera Turbo Sport Turismo: 404 kW (550 hp) between 5,750–6,000 rpm, 770 Nm between 1,960–4,500 rpm

Technical data.

	Panamera 4 E-Hybrid Sport Turismo	Panamera Turbo S E-Hybrid Sport Turismo
Engine		
Type	V6 twin-turbo	V8 twin-turbo
Cylinders	6	8
Displacement	2,894 cm ³	3,996 cm ³
Max. power (DIN) at rpm	340 kW (462 hp) (system) at 6,000 rpm (system)	500 kW (680 hp) (system) at 5,750–6,000 rpm (system)
Max. torque at rpm	700 Nm (system) at 1,100–4,500 rpm (system)	850 Nm (system) at 1,400–5,500 rpm (system)
Transmission		
Layout	All-wheel drive	All-wheel drive
Porsche Doppelkupplung (PDK)	8-speed	8-speed
Chassis		
Front axle	Fully independent aluminium double wishbone suspension	Fully independent aluminium double wishbone suspension
Rear axle	Fully independent aluminium multi-link suspension with chassis subframe, independent suspension	Fully independent aluminium multi-link suspension with chassis subframe, independent suspension
Steering	Power-assisted (electromechanical)	Power-assisted (electromechanical)
Brakes	Six-piston aluminium monobloc fixed brake calipers at front, four-piston units at rear	10-piston aluminium monobloc fixed brakes front, four-piston aluminium monobloc parking brake rear
Standard wheels	Front: 9.0 J x 19 ET 64 Rear: 10.5 J x 19 ET 62	Front: 9.5 J x 21 ET 71 Rear: 11.5 J x 21 ET 69
Standard tyres	Front: 265/45 ZR 19 Rear: 295/40 ZR 19	Front: 275/35 ZR 21 Rear: 325/30 ZR 21

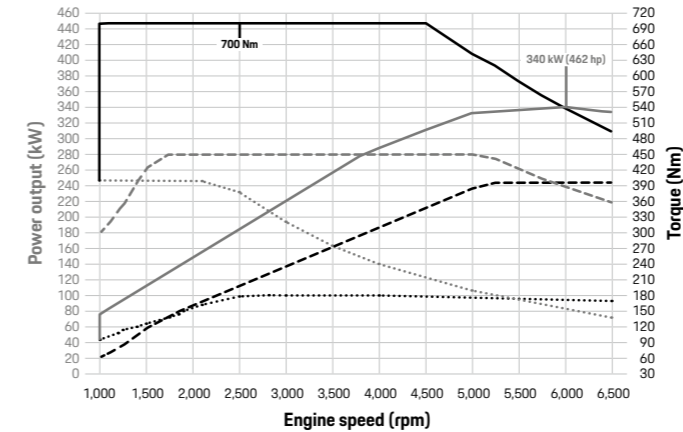

- Panamera 4 E-Hybrid Sport Turismo: 340 kW (462 hp) at 6,000 rpm, 700 Nm between 1,100 and 4,500 rpm
- Panamera 4 E-Hybrid Sport Turismo electric machine: 100 kW (136 PS) at 2,800 rpm, 400 Nm to 2,300 rpm
- - - Panamera 4 E-Hybrid Sport Turismo combustion engine: 243 kW (330 hp) between 5,250 and 6,500 rpm, 450 Nm between 1,750 and 5,000 rpm

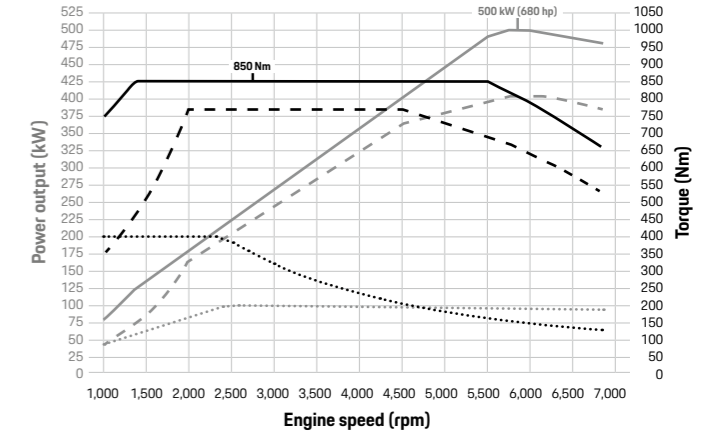

- Panamera Turbo S E-Hybrid Sport Turismo: 500 kW (680 hp) between 5,750 and 6,000 rpm, 850 Nm between 1,400 and 5,500 rpm
- Panamera Turbo S E-Hybrid Sport Turismo electric machine: 100 kW (136 PS) at 2,800 rpm, 400 Nm to 2,300 rpm
- - - Panamera Turbo S E-Hybrid Sport Turismo combustion engine: 404 kW (550 hp) between 5,750 and 6,000 rpm, 770 Nm combustion engine 1,960 and 4,500 rpm

Technical data.

	Panamera 4 Sport Turismo	Panamera 4S Sport Turismo	Panamera Turbo Sport Turismo
Weights			
Unladen weight (DIN)	1,880 kg	1,915 kg	2,035 kg
Unladen weight (EC) ¹⁾	1,955 kg	1,990 kg	2,110 kg
Permissible gross weight	2,550 kg	2,615 kg	2,690 kg
Max. payload	670 kg	700 kg	655 kg
Performance			
Top speed	259 km/h	286 km/h	304 km/h
Acceleration 0–100 km/h	5.5 secs	4.4 secs	3.8 secs
Acceleration 0–100 km/h with Launch Control ²⁾	5.3 secs	4.2 secs	3.6 secs
Acceleration 0–200 km/h	22.7 secs	16.4 secs	13.2 secs
Acceleration 0–200 km/h with Launch Control ²⁾	22.4 secs	16.1 secs	12.9 secs

1) Weight is calculated in accordance with the relevant EC Directives and is valid for vehicles with standard specification only. Optional equipment increases this figure. The figure given includes 68 kg for the driver and 7 kg for luggage.

2) In conjunction with optional Sport Chrono Package.

	Panamera 4 E-Hybrid Sport Turismo	Panamera Turbo S E-Hybrid Sport Turismo
Weights		
Unladen weight (DIN)	2,190 kg	2,325 kg
Unladen weight (EC) ¹⁾	2,265 kg	2,400 kg
Permissible gross weight	2,810 kg	2,900 kg
Max. payload	620 kg	575 kg
Performance		
Top speed	275 km/h	310 km/h
Acceleration 0–100 km/h	–	–
Acceleration 0–100 km/h with Launch Control ²⁾	4.6 secs	3.4 s
Acceleration 0–200 km/h	–	–
Acceleration 0–200 km/h with Launch Control ²⁾	17.1 secs	11.9 s

1) Weight is calculated in accordance with the relevant EC Directives and is valid for vehicles with standard specification only. Optional equipment increases this figure. The figure given includes 68 kg for the driver and 7 kg for luggage.

2) In conjunction with optional Sport Chrono Package (standard in the Panamera 4 E-Hybrid Sport Turismo and the Panamera Turbo S E-Hybrid Sport Turismo).

Technical data.

	Panamera 4 Sport Turismo	Panamera 4S Sport Turismo	Panamera Turbo Sport Turismo
Fuel consumption/emissions¹⁾/Efficiency class²⁾			
Fuel grade	Super Plus unleaded (RON 98)	Super Plus unleaded (RON 98)	Super Plus unleaded (RON 98)
Urban in l/100 km	10.0–9.9	10.4–10.3	13.1–12.9
Extra urban in l/100 km	6.7–6.6	6.9–6.8	7.4–7.3
Combined in l/100 km	7.9–7.8	8.3–8.2	9.5–9.4
CO ₂ emissions combined g/km ³⁾	180–178	189–187	217–215
CO ₂ emissions from fuel and power supply Switzerland in g/km	42–41	44–43	50
Efficiency class Germany ²⁾	C	C	D
Efficiency class Switzerland ²⁾	G	G	G
Dimensions			
Length	5,049 mm	5,049 mm	5,049 mm
Width (including exterior mirrors)	1,937 mm (2,165 mm)	1,937 mm (2,165 mm)	1,937 mm (2,165 mm)
Height	1,428 mm	1,428 mm	1,432 mm
Wheelbase	2,950 mm	2,950 mm	2,950 mm
Luggage compartment volume ⁴⁾ (German Car Manufacturers Assoc.)/with rear seats folded down	520 litres/1,390 litres	520 litres/1,390 litres	520 litres/1,390 litres

1) The figures indicated were determined in accordance with the current version of the measurement method stipulated (EC Directive 715/2007 respectively ECE R 101.1). The figures do not refer to an individual vehicle nor do they constitute part of the offer. They are intended solely as a means of comparing different types of vehicle. Fuel consumption calculated for vehicles with standard specification only. Actual consumption and performance may vary with items of optional equipment. A vehicle's fuel consumption and CO₂ emissions depend not only on its efficient use of fuel but also on driving style and other non-technical factors. All current petrol engines from Porsche are compatible with a fuel ethanol content of up to 10 %. You can obtain further information about individual vehicles from your Porsche Centre. The range of values is dependent on the driving style, traffic situation, route profile, ambient temperature, usage of auxiliary electrical devices (e. g. heating) and number of passengers or load. This may result in the range of values being reduced. The maximum figure was determined in the standard cycle (NEDC), which enables a comparison between manufacturers. In conjunction with comfort memory package. All information regarding construction, features, design, performance, dimensions, weight, fuel consumption and running costs is correct to the best of our knowledge at the time of going to print. Subject to change without notice.

2) Valid in the countries listed only.

3) The average value of the CO₂ emissions of all new cars sold in Switzerland is 133 g/km.

4) The figures stated may vary by country and specification.

	Panamera 4 E-Hybrid Sport Turismo	Panamera Turbo S E-Hybrid Sport Turismo
Fuel consumption/emissions¹⁾/Efficiency class²⁾		
Fuel grade	Super Plus unleaded (RON 98)	Super Plus unleaded (RON 98)
Urban in l/100 km	–	–
Extra urban in l/100 km	–	–
Combined in l/100 km	2.6 (4.3)	3.0 (4.9)
CO ₂ emissions combined g/km ³⁾	59	69
Electricity consumption, combined, in kWh/100 km	15.9	17.6
CO ₂ emissions from fuel and power supply Switzerland in g/km	36	40
Efficiency class Germany ²⁾	A+	A+
Efficiency class Switzerland ²⁾	D	E
Typical all-electric range in everyday driving ⁴⁾	25–51 km	25–49 km
Dimensions		
Length	5,049 mm	5,049 mm
Width (including exterior mirrors)	1,937 mm (2,165 mm)	1,937 mm (2,165 mm)
Height	1,428 mm	1,432 mm
Wheelbase	2,950 mm	2,950 mm
Luggage compartment volume ⁵⁾ (German Car Manufacturers' Assoc.)/with rear seats folded down	425 litres/1,295 litres	425 litres/1,295 litres

1) The figures indicated were determined in accordance with the current version of the measurement method stipulated (EC Directive 715/2007 respectively ECE R 101.1). The figures do not refer to an individual vehicle nor do they constitute part of the offer. They are intended solely as a means of comparing different types of vehicle. Fuel consumption calculated for vehicles with standard specification only. Actual consumption and performance may vary with items of optional equipment. A vehicle's fuel consumption and CO₂ emissions depend not only on its efficient use of fuel but also on driving style and other non-technical factors. All current petrol engines from Porsche are compatible with a fuel ethanol content of up to 10 %. You can obtain further information about individual vehicles from your Porsche Centre. The range of values is dependent on the driving style, traffic situation, route profile, ambient temperature, usage of auxiliary electrical devices (e. g. heating) and number of passengers or load. This may result in the range of values being reduced. The maximum figure was determined in the standard cycle (NEDC), which enables a comparison between manufacturers. In conjunction with comfort memory package. All information regarding construction, features, design, performance, dimensions, weight, fuel consumption and running costs is correct to the best of our knowledge at the time of going to print. Subject to change without notice.

2) Valid in the countries listed only.

3) The average value of the CO₂ emissions of all new cars sold in Switzerland is 133 g/km.

4) Range varies with driving style, traffic, route profile, outside temperature, use of electrical auxiliary consumers (e.g. heating) and number of passengers/payload. Actual range may even be less than the range stated. The upper value has been determined in the NEDC, a standardised driving cycle enabling comparison between manufacturers.

5) The figures stated may vary by country and specification.

Tyre table.

Tyre type	Size	Fuel efficiency class/ rolling resistance	Wet grip class	External rolling noise* (class)	External rolling noise (dB)
Panamera					
Summer tyres	265/45 ZR 19	C-B	B-A	🔊 – 🔊	73-69
	295/40 ZR 19	C-B	B-A	🔊 – 🔊	75-70
	275/40 ZR 20	C	A	🔊	73-71
	315/35 ZR 20	C-B	A	🔊 – 🔊	73-70
	275/35 ZR 21	C	B-A	🔊	73-71
	315/30 ZR 21	C	B-A	🔊 – 🔊	75-70
	325/30 ZR 21	C	B	🔊	73

For logistical and technical reasons relating to the production process, we are unable to accept orders for a particular make of tyre.

* 🔊 Quiet rolling noise, 🔊 Moderate rolling noise, 🔊 Loud rolling noise.



Index.

A	D	L								
Adaptive air suspension	55	Design	16	Lane Change Assist	101	Performance display	62	Porsche Traction Management (PTM)	53	T
Adaptive cruise control (ACC)	97	Digital radio	150	Lane Keeping Assist	101	Personalisation	107	Porsche Vehicle Tracking System (PVTS)	92	Technical data
Adaptive cylinder control	40	Direct fuel injection (DFI)	40	Launch Control	65	Porsche 4D Chassis Control	55, 56	Power output	14, 40, 45, 46	Telephone module
Air conditioning	83, 141	Direct Touch Control	25	LED main headlights including Porsche Dynamic Light System (PDLS)	94	Porsche Active Suspension Management (PASM)	56	Privacy glass	141	Theft detection
All-wheel drive	53	Drive	39	LED main headlights with matrix beam including Porsche Dynamic Light System Plus (PDLS Plus)	94, 141	Porsche Advanced Cockpit	25, 71			Touchscreen display
Ambient lighting	76, 133	Driving modes	48, 62	Light-alloy construction	66	Porsche Car Configurator	154			25, 48, 71, 83, 88
Apple® CarPlay	92					Porsche Car Connect	92	R		99
Assistance systems	97	E				Porsche Ceramic Composite Brake (PCCB)	58, 132	Radio	88	Traffic Jam Assist
Audio interface	88	Engines	40, 42	M		Porsche Communication Management (PCM)	88	Real-time traffic information	91	101
Audio systems	84	Environment	66	Massage function	79	Porsche Connect	88	Rear-axle steering	55, 133	Transmission
Auto start/stop function	40, 66	Exterior	139	Mobile phone preparation	88	Porsche Connect Portal	92	Recycling	66	51
				Multi-plate clutch	53	Porsche Connect Store	92	Reversing camera	102	101
B	F					Porsche Doppelkupplung (PDK)	51			Turn Assist
BOSE® Surround Sound System	84	Factory collection	151, 155	N		Porsche Dynamic Chassis Control Sport (PDCC Sport)	56	S		40
Brakes	58	Fuel	66, 166	Navigation	88, 91, 92	Porsche Dynamic Light System (PDLS)	94	Safety	143	88
Burmester® High-End				Night Vision Assist	94	Porsche Dynamic Light System Plus (PDLS Plus)	94	Seat heating and ventilation	79	
3D Surround Sound System	87	H				Porsche InnoDrive	98	Seats	79, 142	
		Headlights	94, 141	O		Porsche Rear Seat Entertainment	72	Sound systems	84	W
C	I			On-board computer	75	Porsche Stability Management Sport (PSM Sport)	65	Speed limit indicator	75	61
CD/DVD drive	88			Online navigation	88	Porsche Torque Vectoring Plus (PTV Plus)	56	Sport Chrono Package including mode switch	62	
Chassis	55	I						SPORT mode	48, 62, 65	
Coasting	66	Infotainment	68	P				SPORT PLUS mode	48, 65	
CoLOURS	118	Instrument cluster	75	Panoramic sunroof	23, 132			SPORT Response	65	
Colours	118	Interior	71, 120, 124, 144	ParkAssist	102			Surround View	102	
Comfort	68, 143	Interior lighting	76	Payload	164, 165					
Connect apps	92	Interior packages	123, 130							
Connect Plus module	91	Ioniser	83							
Connect services	91									
Cornering notification	101									



